

THERMOSTAHL POLAND

MULTI-OIL BURNER type MULTIMAX MTX 65

SERVICE AND INSTALLATION MANUAL



ver. 1/2016

THERMOSTAHL POLAND Sp. z o.o.

Al. Wojska Polskiego 42B, 05-800 Pruszków

tel./fax: +48 22 758 40 96, 0-692 460 887

e-mail: thermostahl@thermostahl.pl, Internet: www.thermostahl.pl

Technical specifications:

Type		MTX 65
Burner power - min.	kW	17
Burner power - max.	kW	65
Burner power - min.	kcal/h	114
Burner power - max.	kcal/h	55
Max. fuel consumption	l/h	6.6
Power supply	V/Hz	230/50
Fuel connection		insulated line 1/4", length 1100 mm, 3/8" connector
Motor ventilator - 2750 rpm	W	90
Capacitor	μ F	3
Ignition transformer	kV	15
	A	0.25
Weight	kg	15.5
Protection type		float, photo-optical, thermal sensors
Heating container heater	W	500
Fuel rod heater	W	200
Packaging dimensions	mm	515 x 400 x 410
Minimum compressor requirements	l/m-bar	63-2.5

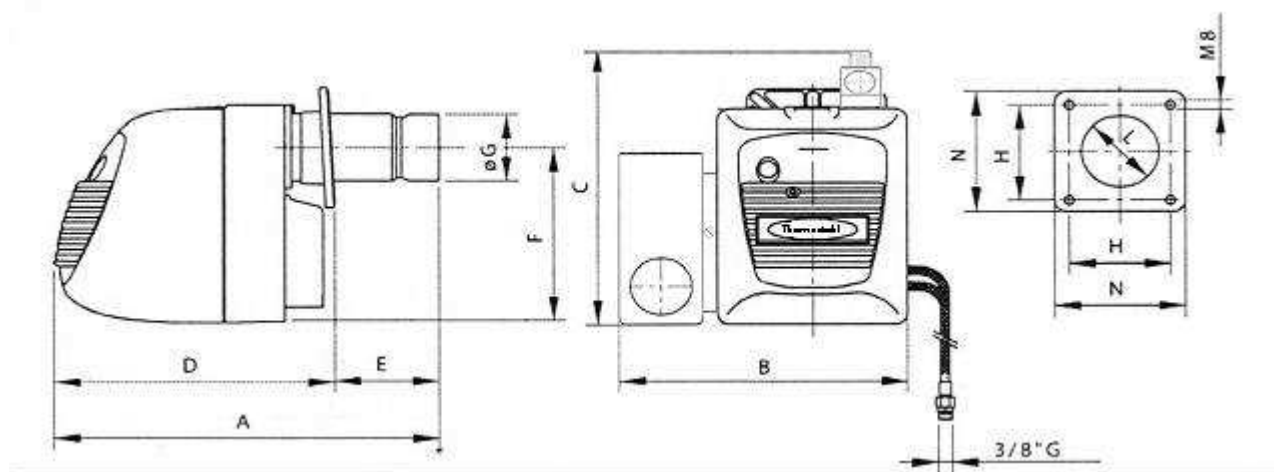

MODEL	A	B	C	D	E	F	Ø G	H	Ø L	N
MTX 65	490	350	390	370	60-120	232	89	90-140	95	160

Introduction:

The MTX burner is a low-pressure burner with an injector nozzle, designed for use with the following fuel types:

- waste oil (engine oil, gearbox oil, hydraulic oil, plant oil, etc.),
- medium fuel oil
- light fuel oil
- diesel fuel

NOTE!

Do not use transformer oil, capacitor oil, petroleum and thinners!

The MTX burner requires a compressed air supply, with the air supply depending on the set power, with which the burner is supposed to operate. For example, we assume minimum compressor capacity requirements of 60 l/min. at a pressure of 2.5 bar.

These are parameters provided by even the smallest units with small air containers. We encourage, however, to use compressors with tank capacities of 80-100 litres, thanks to which the compressor operation pause times can be extended. In case of the burners being installed at spots where the noise levels can be high, we suggest using screw compressors or medical compressors, the noise levels of which amount to 45-50 dbA.

Burner description

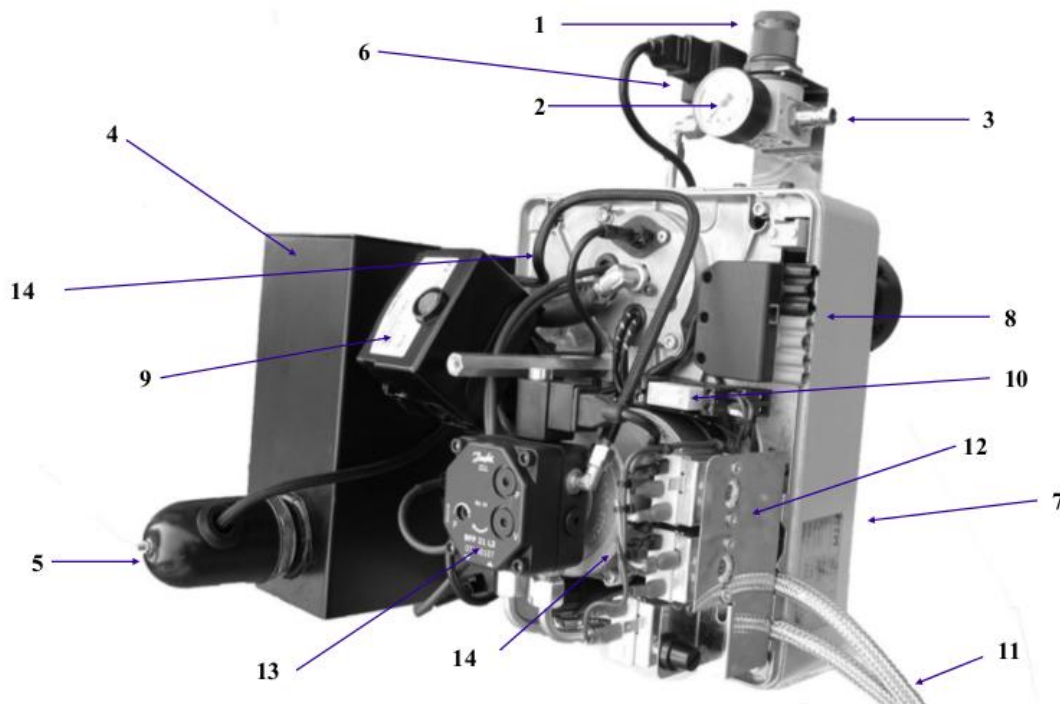

Fig. 1.

- | | |
|-------------------------------|---|
| 1. Spray air pressure reducer | 9. LMO 14... control automatic unit |
| 2. Air pressure gauge | 10. Main heater relay |
| 3. DN air connector coupling | 11. Oil lines (supply and return) |
| 4. Distribution tank | 12. Heater control thermostat units and protection fuses. |
| 5. Fuel heater | 13. Oil pump |
| 6. Air solenoid valve | |
| 7. Secondary air adjustment | |
| 8. Power connector (Euro) | |

Fig. 2. Heating tank

1. Heater
2. Nozzle rod supply fuel line
3. Tank supply fuel line
4. Thermostat and fuse capillary line
5. Fuel overflow floater sensor
6. Tank supply floater sensor

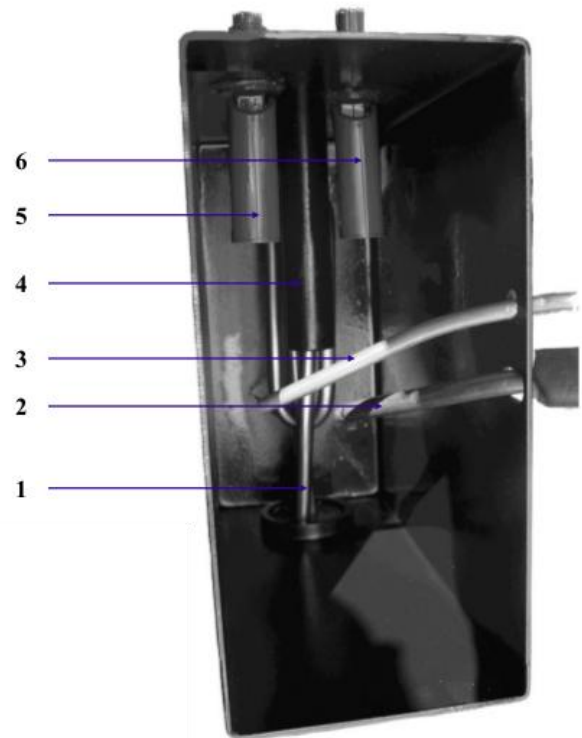

Fig. 3. Adjustment of compressed air supplied for fuel combustion



Important items that need to be taken care of before installation of the burner

- The permitted maximum temperature for the room, in which the burner operates, is 45 °C, the minimum temperature is 8 °C.
- The electric set-up must be conducted by qualified personnel, according to relevant local country standards, as well as according to current rules of the local energy company.
- The boiler or heater should be prepared for installation of the burner according to manufacturer instructions. If a boiler or heater is used, always check its technical condition with utmost precision, and any flaws need to be removed. Keep in mind that the size of the combustion chamber of the boiler used conditions the achievement of a proper burner power value.
- When configuring a coal boiler with the MTX 65 multi oil burner, one runs the risk of incomplete fuel burning and the collection of oil in the combustion chamber.
- Before start-up, check the chimney ducts for lack of obstructions and tightness.
- The internal surface of the chimney needs to be smooth, it is not permitted to use ducts of types Flex, Spiro, or of other similar materials. A brick chimney should have a liner made of acid-resistant steel. The use of brick chimneys and inappropriate materials shall cause obstructed removal of exhaust fumes from the boiler, and shall consequently lead to soot build-up in the boiler, which will cause problems with the burner operation. The chimney should be executed as straight, in difficult conditions it is permissible to use elbows with a maximum angle of 45° (applies solely and only to short chimney sections). Under no circumstances may the chimney be laid out horizontally. The chimney system should be routed to the outside to 500 mm above the highest point of the building so that air turbulences would not influence changes in the draught. Use a canopy to conclude the chimney, with the free space between the outlet of the pipe and the lower edge of the canopy being not less than the chimney pipe diameter. Use a double-jacket insulated pipe as the outer part of the chimney in order to reduce condensation.
- A very important component of the chimney is the use of a chimney draught adjuster that will maintain a constant underpressure value in the combustion chamber.

Fig. 1.

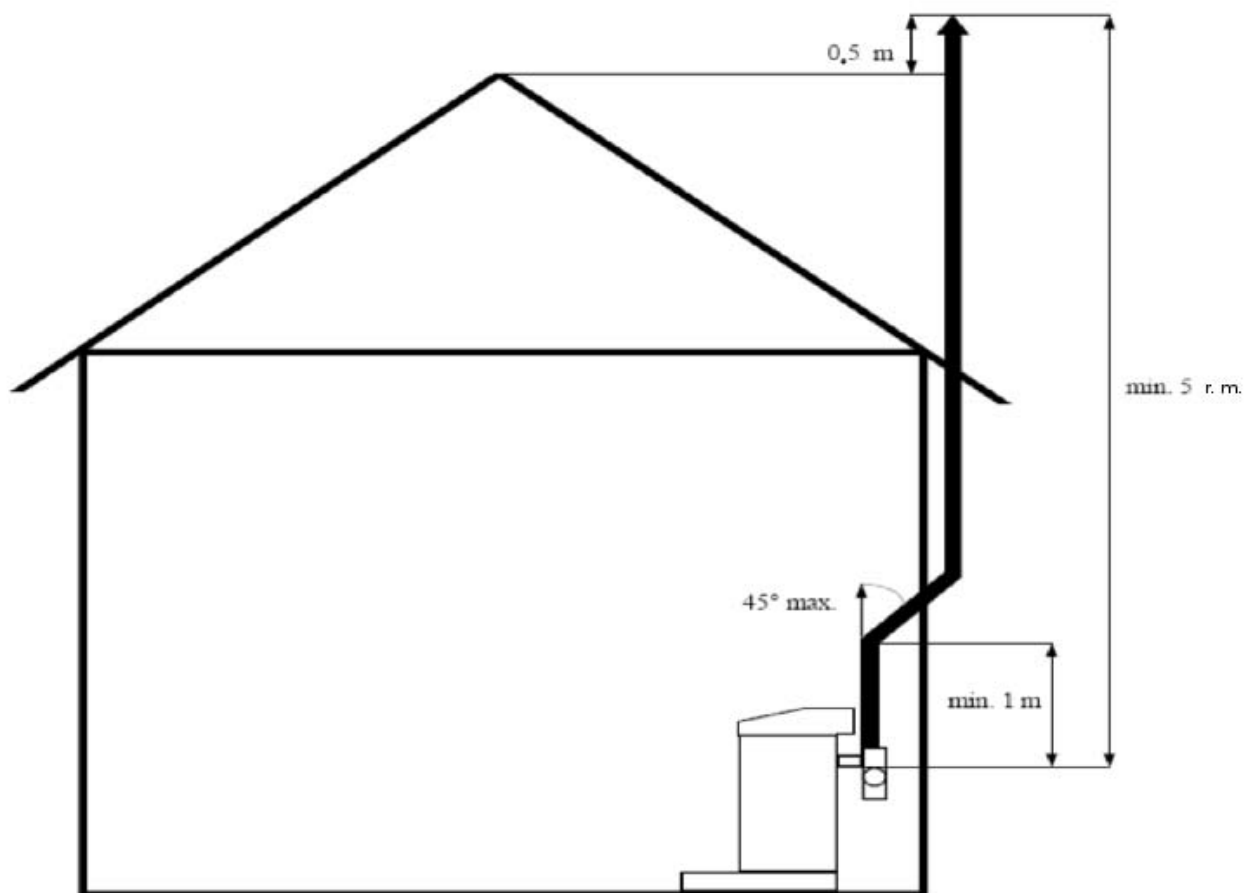
**Chimney draught adjustment**

Multimax MTX 65 - technical documentation

- A correct chimney draught is one of the most important factors ensuring proper and safe use of any boiler. Before adjusting the draught, please study all safety rules and instructions contained in this manual. Such adjustment may only be performed by qualified personnel equipped with appropriate devices.

Draught control

- Introduce the draught probe on the outlet pipe
- Adjust the chimney draught to 0.2 pressure level
- The chimney draught should not exceed 0.3 of the pressure level, as this runs the risk of overheating the chimney and loss of thermal power.

Draught adjustment

- Chimney draught adjustment entails shifting the counterweight on the adjustment unit cover (fig. 4), until an appropriate value is reached on the measurement device. If you are not able to achieve an optimum draught value, contact a service company.

WARNING!

It is very important to properly adjust the draught.

Fig. 4

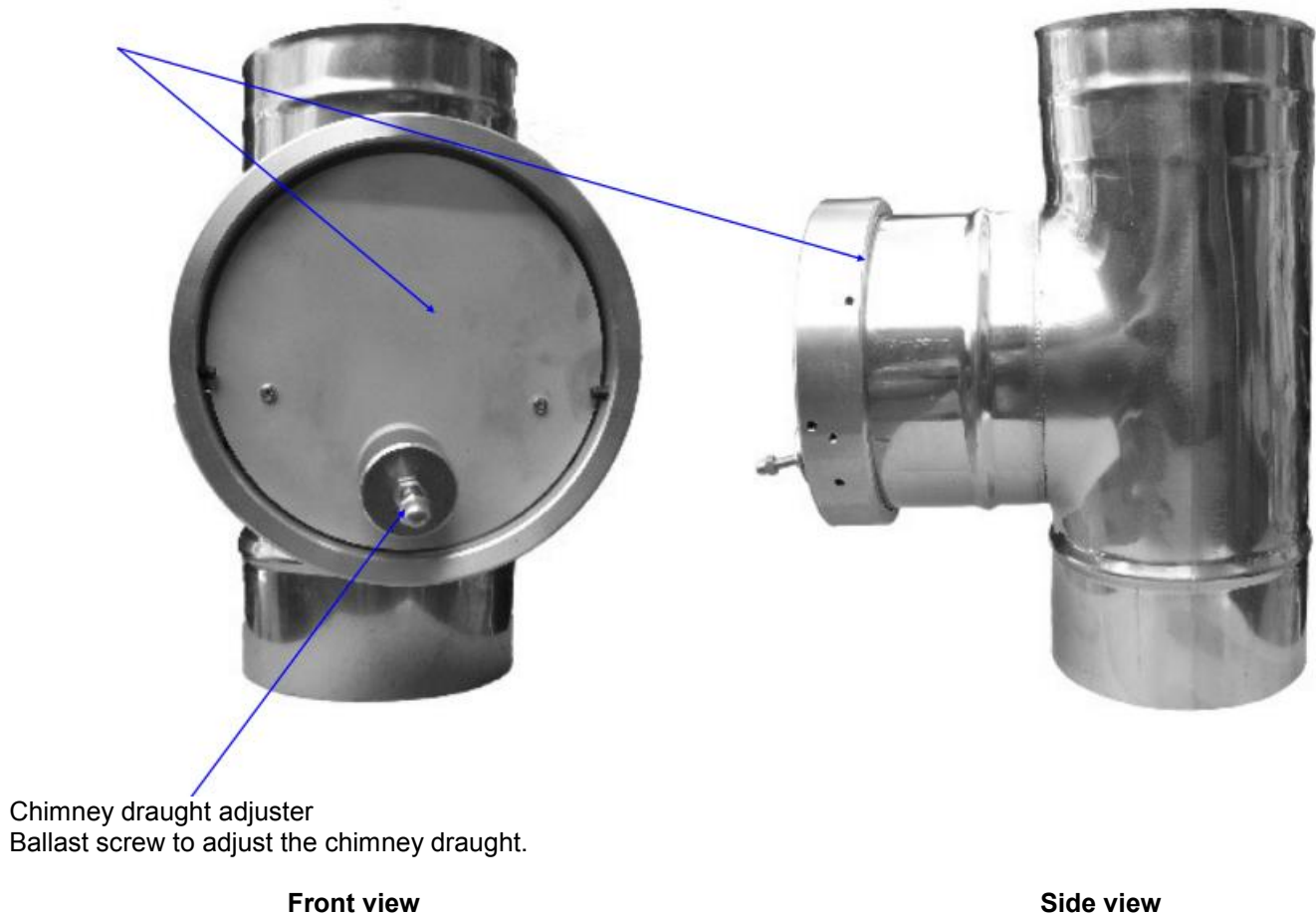

The chimney needs to be cleaned at least three times during a single cleaning period.

A clogged up chimney liner may cause the soot catching fire, a consequence of which might be it blowing up outside the house, risking a grand fire.

Fuel system

- The fuel supply system should be executed out of soft or hard copper, and have a minimum diameter of 10 mm. The maximum length of the fuel system for the MTX 65 burner is seven running metres. The fuel system requires absolute tightness. Any, even the most minute, leaks that may even be invisible, shall introduce air into the system and thus prevent proper operation of the burner.
- To check the tightness of the fuel system, create underpressure in the system. By generating overpressure, in very rare cases one may bring about self-tightening of the fuel system (dependent on the structure of the fuel system).
- The simplest way to check the tightness of a fuel system is to disconnect the flexible fuel hose from the fixed fuel installation side, and supplying it from any clean fuel storage unit. Keep in mind that in such a case the fuel is not filtered. The flexible hose needs to be placed in a fuel tank so that the end of the suction line does not lie on the bottom of the container. Deciding to use such a momentary connection, remember that after a short stint of operation of the burner, one can lead to the filter within the fuel pump getting clogged.

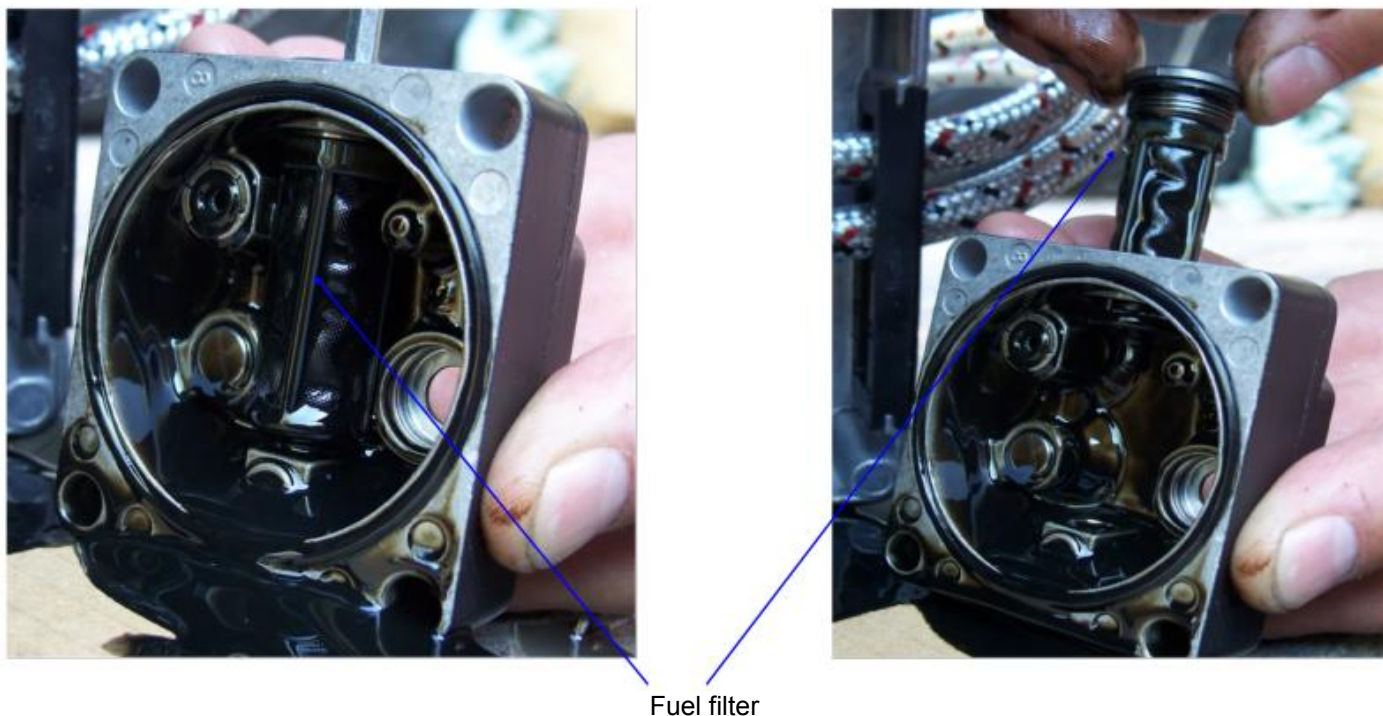

Fig. 5.

WARNING! Remove the fuel filter only and exclusively if the burner is switched off. Remove the plug with the hexagonal opening, found on the top part of the pump closing cover, in order to dismantle it.

- The total length of the supply line is calculated as the sum of all horizontal, vertical and elbow sections of it.
- The static height value of H - up to two metres - is considered to be the difference in placement of the fuel pump, the burner and the suction nozzle, found within the fuel storage tank. Suction resistance should not exceed 0.02 MPa. Should the underpressure value increase, the burner pump may experience excessive suction resistance, which as a result will permanently damage the pump.
- The most profitable way to power the burner is to place the fuel tank above the supply pump, as such a system shall cause the fuel pressing on the burner, thanks to which the fuel suction resistance values are reduced.

VERY IMPORTANT! The minimum temperature value for the fuel in the tank is 5 °C

Diagram of connection of the fuel system to the MTX 65 multi oil burner

length of fuel system - up to 7 r. m.

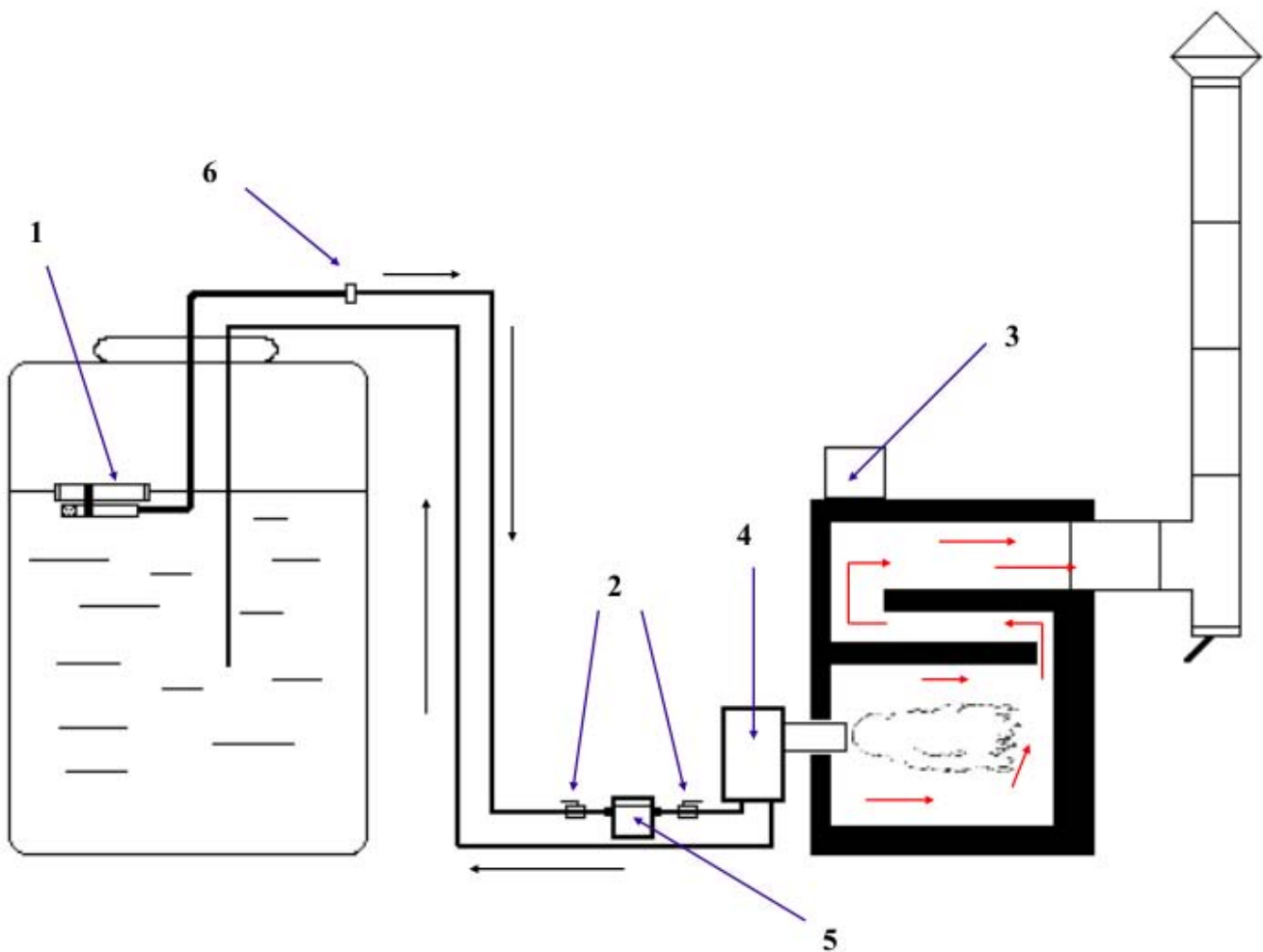

Fig. 2

1. Suction floater with return valve
2. Cutoff valves (option of severing the burner for service and maintenance and filter cleaning)
3. Automatic units
4. MTX 65 burner
5. Oil filter
6. Connector nipple between fixed system and floater sensor.

MTX 65 burner operating principle

The MTX burner is a low-pressure device equipped with an injector nozzle. The fuel, through a copper tube, is sucked to the nozzle from the heating tank with the use of compressed air, which is provided to it using a separate duct. The fuel is premixed with air in the nozzle itself. The fuel, leaving the nozzle, is spun up using a special plate found at the end of the flame pipe, and enriched with a further volume of air provided by the burner fan. At the end of the flame pipe, just over the nozzle, the ignition electrode is placed, which provides an electric arc igniting the fuel-air mix.

BURNER OPERATING CYCLES

- Blowout phase - Solenoid valve closed, the combustion chamber is blown through
- Mix ignition phase - Solenoid valve opens, the fuel-air mix is ignited
- Operation phase - Following the mix ignition, the burner operates until it receives a shutoff signal, following which the air solenoid valve closes.

If no flame is visible after the ignition phase, the burner switches into an error mode, indicating a flaw by lighting up a red diode on the burner control panel. In order to restart the burner and start up the blowout cycle, press the backlit button on the burner control unit.

WARNING! In order for the burner to exit the error mode, press the red-lit automatic unit button. Apart from this, however, for safety reasons, the burner shall begin the blowout cycle only after one minute has elapsed from it switching into error mode. Pressing the button before this time shall be ignored by the automatic circuitry.

If after this restart the burner still does not start up, check all parameter settings and, if need be, readjust the burner again.

The adjustment of the volume of fuel provided by the nozzle is done just above the burner (reducer unit with gauge, fig. 1, item 1.1.). The burner operating range is set using the reducer unit knob (lift the knob to release its lock), reading it out from the manometer. The manometer should indicate a value between 0.4 bar and 1.1 bar.

Fuel consumption:

Assuming a fuel calorific value of about one litre = 8200 kcal = 9,53 kW (burner capacity 17-65 kW).

- Fuel temperature in tank = +16 °C
- Fuel temperature in fuel preheating tank ~+60 °C

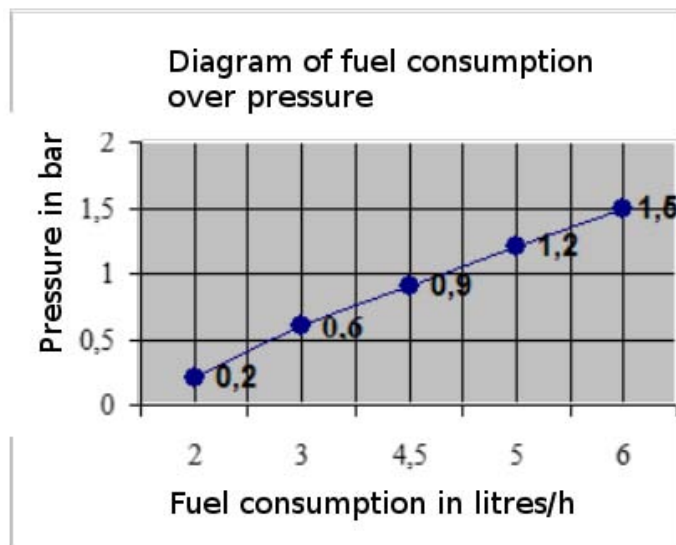

**Practical suggestions concerning heater adjustment
(fuel-air mix rate)**

Any interference in the operation of the burner is very often caused by errors of the operator (used). Following a first start-up and adjustment of the burner by qualified service personnel, every user intervention causing changes to settings, and in particular settings concerning the fuel and air, may lead to the combustion chamber and boiler exchanger or air heater becoming unbalanced, and, consequentially, blocked and sooted over. After thorough cleaning of the boiler or heater and reinstallation of the burner, we suggest starting up the system in the following manner:

1. Before start-up, adjust the primary air throttle (fig. 3) to position '3' - carry out this operation very carefully.
2. Start up the burner, attempting to set the fuel volume value with the adjustment unit (fig. 1, item 1), reading out the value of 0.7-0.8 MPa from the gauge. This adjustment is carried out when the air solenoid valve opens (audible click). When the flame becomes visible, after about twenty seconds, the user should attempt, turning the air adjustment throttle (fig. 3) towards the '+' direction, to provide as much air as possible, causing the flame to change colour - it should be as bright as possible. The surplus air can cause start-up difficulty after the burner shuts down, due to the electric arc and flame being blown away. In such a situation gently turn the air adjustment throttle in the '-' direction, thus reducing the volume of air pumped into the combustion chamber.

Visual flame adjustment

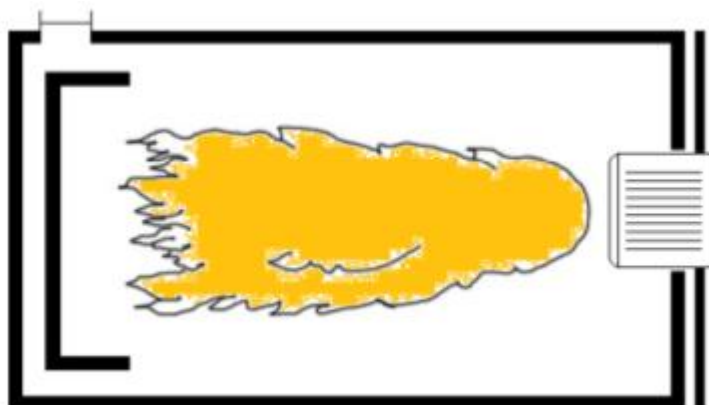

Correct flame - the end of the flame reaches to 2.5-5 cm (1-2 inches) before the deflector. Flame length needs to be checked periodically - initially once a week, later on once a month.

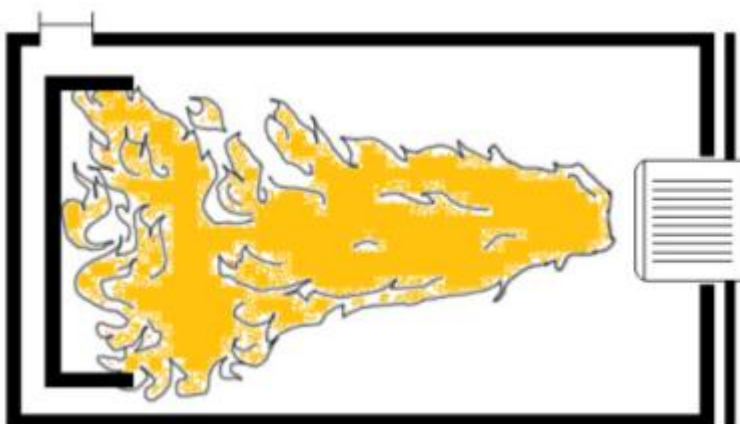

Incorrect flame - excessive oil pressure - remember not to overheat the furnace, as it will greatly reduce its usable lifetime. The flame must not reach the deflector. Noticing changes to the flame length, immediately change the parameters of the burner.

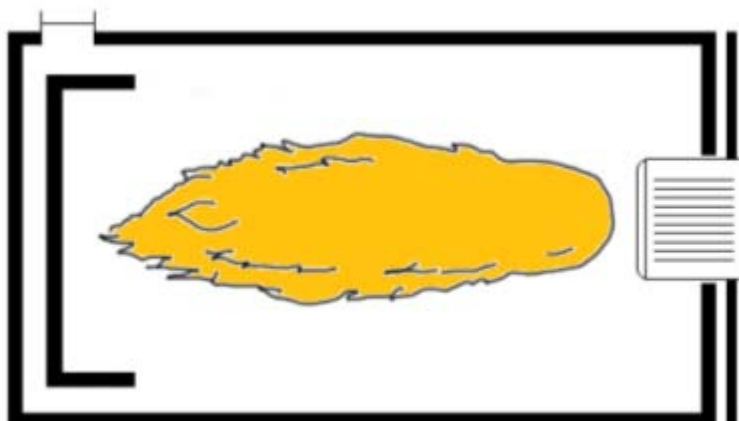

Incorrect flame - excessive air pressure - such a flame is equally damaging as the one above, and needs to be corrected quickly.

WARNING! Watching the chimney is also a very important factor and indicator. The exhaust fumes should not be visible. If dark or black smoke emerges, appropriately adjust the heater immediately.

It can often occur following cleaning of the boiler that the unit may produce some smoke due to the combustion of cleaning fluids and agents.

The adjustment procedure described above applies to heating devices having a low thermal power. Each increase of the fuel efficiency by the adjustment unit (photo 1, item 1) must be accompanied by adjustment of the air flow (photo 3) - as described above).

Distribution (heating) tank:

Topping up the distribution tank is affected by opening the fuel solenoid valve on the pump, which is controlled by a floater (photo 2, item 5). In case trouble should emerge with respect to topping up the fuel tank after checking the tightness of the fuel system and cleanliness of the filters, clean the floater unit and test it. As a result of the lower floater being flooded over, the burner is shut off the moment the safety floater is raised (photo 2, item 6). In such a case contact the service department immediately to replace the floater.

In the distribution tank, connected thermocouples are placed (safety thermocouple and fuel temperature adjustment thermocouple) - photo 3, item 4.

The placement of the thermocouples is of paramount importance. They need to be installed horizontally at the height of the fuel uptake line leading to the nozzle (photo 3, item 2). Moving the thermocouples to a different depth could cause grave damage to the burner.

The standard temperature set on the adjustment unit (photo 6) is 60 °C.

SETTING THE ADJUSTMENT BOLT CONTROLLING THE FUEL TEMPERATURE IN THE DISTRIBUTION TANK

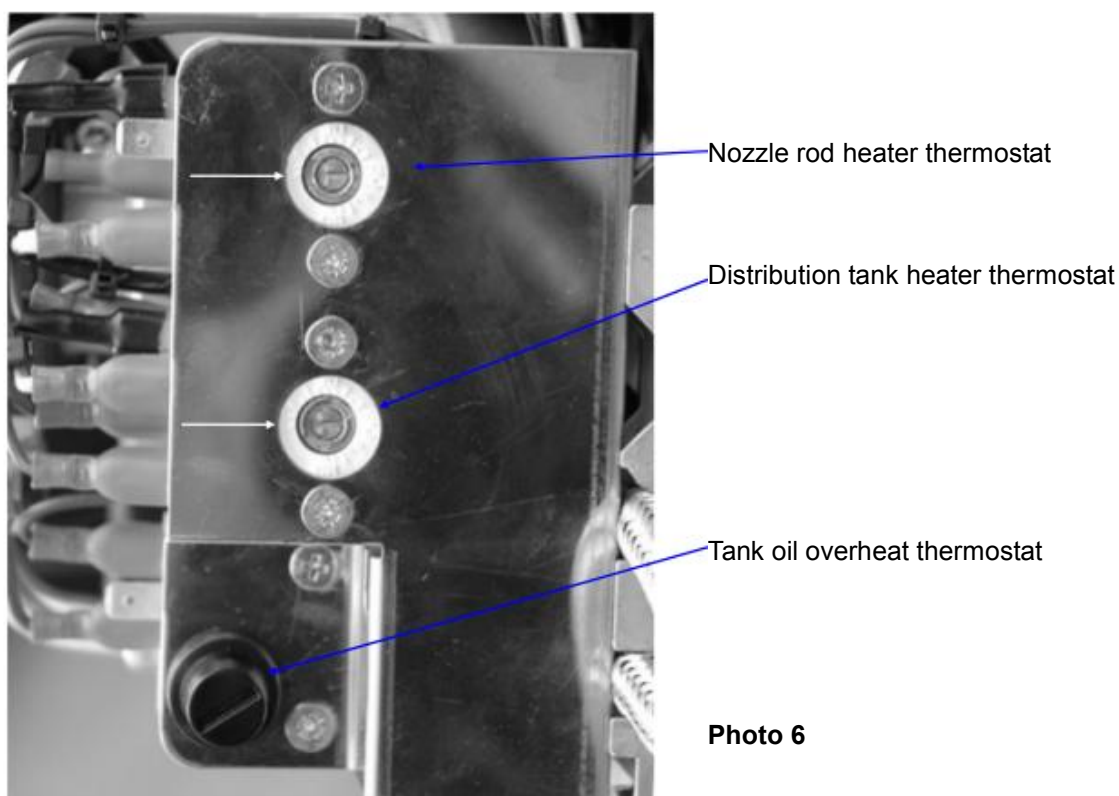

WARNING! Do not exceed the temperature of 90 °C. Any higher temperature poses a risk to the thermocouples and presents the hazard of the floater sensors burning away.

The safety thermostat (photo 6) prevents the fuel in the distribution tank from overheating. A typical sign of the actuation of this thermostat is lack of connected voltage and the inability to start the burner. In order to reset this thermostat, unscrew the black cap close to the thermostat units and manually press the button located underneath.

The above actions need to be executed after the fuel in the distribution tank has cooled.

WARNING! Frequent actuation of this thermostat may be caused by:

- damage to the fuel temperature control thermocouple - call the service department for assistance
- direct adherence of the thermocouples to the heater.

Maintenance work, filter cleaning

WARNING! Your furnace requires periodic maintenance in the same fashion as cars or other machinery with moving parts do. The timely execution of periodic checks may markedly increase the lifetime of your furnace. Periodic inspections are a necessary condition of warranty continuation.

Service activities

- Fuel filter cleaning
- Removal of ash from the combustion chamber
- Cleaning out the water and any deposits from the tank
- Adjustment and inspection of the general condition of the burner.

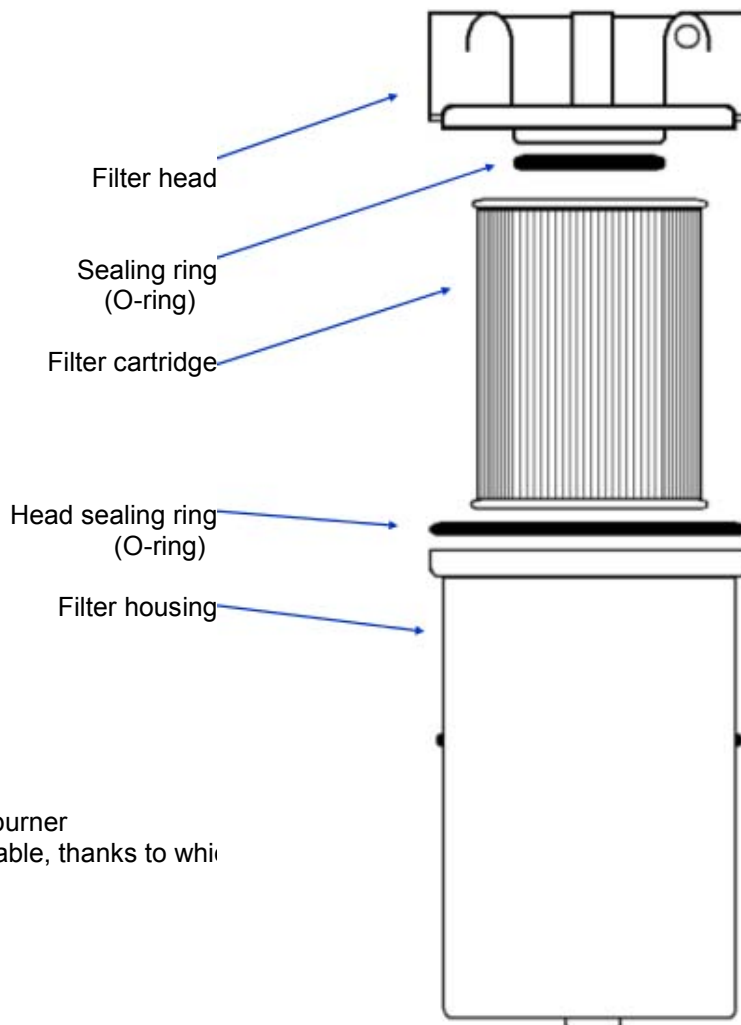

Warning! Oil filters recommended by the burner manufacturer, THERMOSTAHL, are washable, thanks to which cartridges may be reused.

Fig. 3

Cleaning the precision cleaning filter

- Close the valves upstream and downstream of the fuel filter
- Place a container under the filter, unscrew the mounting bolt and remove the filter housing.
- Remove the filter cartridge (clean the filter in such a way so that the grime and contaminants do not enter it, use compressed air pumped to the inside of the filter cartridge to ensure its effective cleaning).
- Clean and wash thoroughly all filter components.
- Check the sealing elements - those that are worn or with visible signs of wear need to be replaced.
- Fill the filter housing with fuel and mount it on the head.
- Check connection tightness and seal.
- Open the oil line valves.

WARNING! Removal of the filter is only carried out with the fuel line valves closed and the burner shut off.

Cleaning the fuel pump filter

The filter of the fuel pump is shown in photograph 5. It is placed inside the pump. In order to remove it, unscrew the filter cap on the top part of the pump cover. Use a 5 mm hexagonal key to unscrew the cap.

Cleaning the riser plate and ignition electrodes

Fig. 7.

After the burner has been disconnected from the electric, fuel and compressed air lines, loosen the tightening screw of the flange and slowly and carefully take out the flame pipe from the combustion chamber. Then, execute the following:

- Clean out the contaminants from the entire unit and the grooves between the plate fins.
- Clean the ignition electrodes carefully so that their arrangement does not change accidentally.

Warning! Never screw away the nozzle from the fuel rod, as this may cause loss of tightness of the fuel rod, and as a result, wrong operation of the burner or complete damage to it.

Technical difficulties - causes and remedies

Symptoms	Causes	Remedies
Motor does not work	Blocked fan or fuel pump	Remove the cause
	Safety thermostat actuated	Reset safety thermostat
	Capacitor failure	Replace
	Motor failure	Replace
Burner does not start up due to lack of fuel in the burner tank	Air captured in the system due to all fuel from the distribution tank being pumped away	Following fuel top-up deaerate system, do not permit the tank from becoming completely empty
	Manual shutoff valve on system is closed	Open
	Contaminated system fuel filter	Clean
	Contaminated pump fuel filter	Clean
	Worn pump (dry run)	Replace
	Damaged tank fuel level adjustment unit or unit not configured properly	Remove flaw, configure appropriately
	No voltage on the pump solenoid valve	Remove flaw
Pump operation noise	Pump takes in air	Tighten screw connections, check system tightness. Use flow heater
	Excess fuel density	
	Too low fuel temperature	Configure
	Excessive air pressure	Configure
	Excessive system underpressure value	Clean, check correctness of choice of fuel supply line diameter
No ignition	Shorted ignition electrodes or electrodes too far apart	Configure appropriately
	Wet or contaminated ignition electrodes	Clean
	Ignition device defective	Replace
	HV cabling damaged	Replace

	Foreign light in combustion chamber (photocell current during burner pause period)	Close combustion chamber viewer on boiler
	Photocell damaged	Replace
	Too low fuel temperature	Set properly
	Excessive air pressure	Set properly
	Control unit failure	Replace
Asymmetric spraying	Spray nozzle channels partially contaminated	Clean
	Nozzle worn due to long life	Replace nozzle (exclusively the service department!)
	Bad arrangement of ignition electrodes (electrodes in the fuel spray cone)	Set properly
	Contaminated plate from the flame side	Clean
	Contaminated heat exchanger (boiler) causing asymmetric chimney draught	Clean
	Lack of tightness of exchanger in exhaust gas path (false air)	Tighten
	Bad arrangement of the plate (the spray air cone touches upon an edge of the plate).	Set properly
Strong dripping from nozzle	Low air pressure	Check system, compressor
	Damaged air solenoid valve	Replace, clean
	Unstable underpressure values in boiler	Attach chimney draught adjuster
	No power supply to air solenoid valve	Remove flaw
Air and fuel comes out of nozzle, despite burner position fixing	Damaged air solenoid valve	Clean or replace
Solenoid valve does not open or close	Valve coil or cable defective	Replace
	No electric connection	Remove failure
	Damage to solenoid valve	Replace
Solenoid valve does not open or close	Solid particle on seal (does not close)	Replace
	Control unit failure	Replace
Strong contamination of plate and boiler with soot	Contamination to air system (fan, air intake system)	Clean, ensure cleanliness in the room

	Bad burner adjustment	Adjust properly
	Broad temperature variations in the air taken in by the burner	Ensure stable ambient air temperature
	Burner with boiler placed in room with no stable air inflow	Ensure air supply
	Bad arrangement of electrodes and plate	Set properly
	Defective nozzle	Replace (service department only!)
	Fuel type change (new fuel provided)	Adjust
	Change of air volume due to increase of exhaust gas flow as a result of combustion leftover substances collecting in the boiler	Clean the boiler periodically
Oil outflow from boiler	Oil spillage	Raise the boiler on the burner side by about 3 cm
Oil outflow from burner	Oil spillage from burner	Install the burner in the boiler in a 'diving' position.

Euro 7 pin connection diagram

Euro socket plug

B4 *	Fuel pump
S3 *	Burner flaw indicator
T2 *	Signal from external thermostat
T1 *	Signal to external thermostat
N *	Burner working zero
PE *	PE protective wire
L1 *	Burner power supply at 230 V, 50 Hz

MTX 65

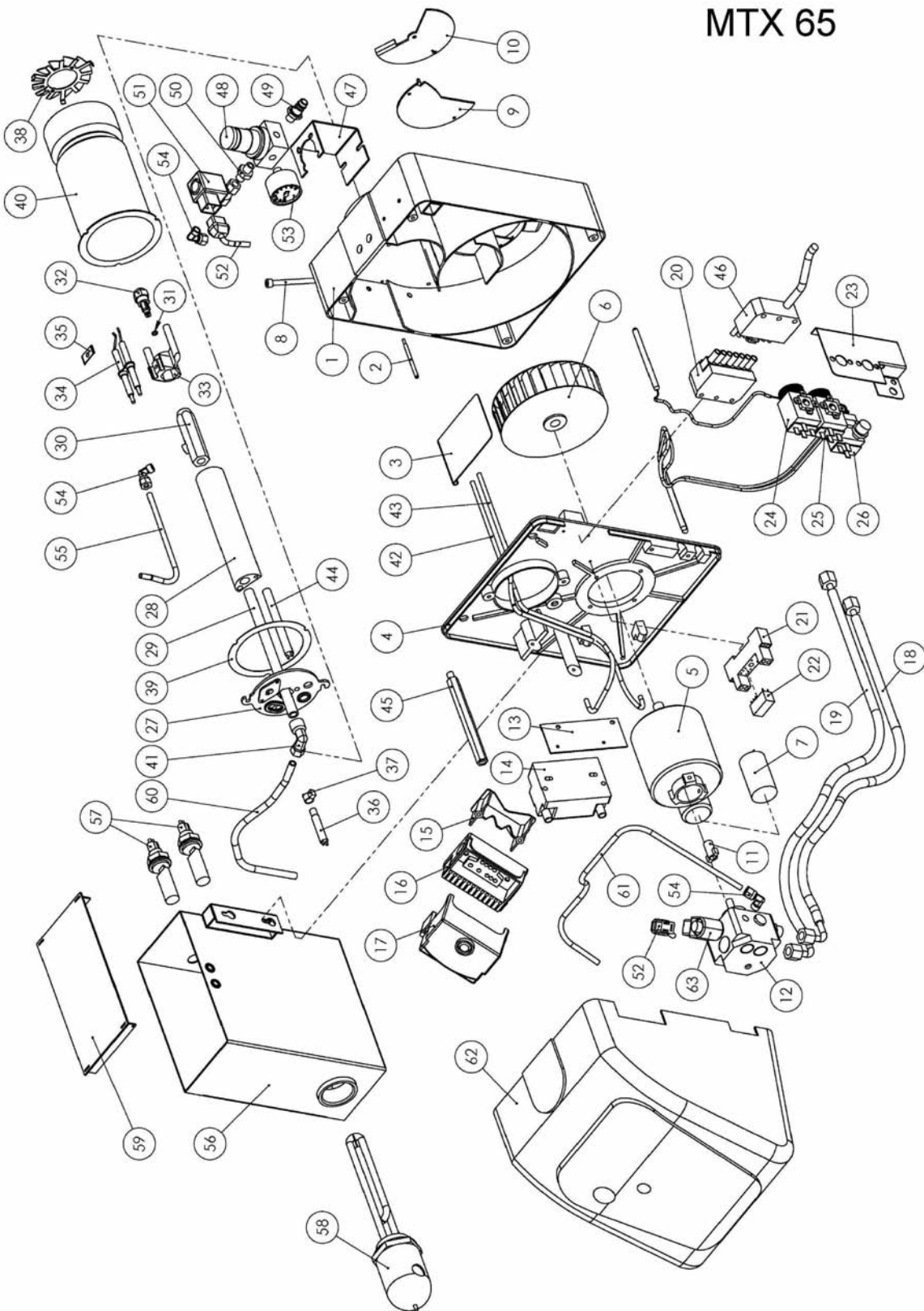

NO.	COMPONENT NAME	ATALOGUE NUMBER COUN	
1	Body	001.10	1
2	Throttle axis	001.11	1
3	Air throttle	001.12	1
4	Partition plate	001.13	1
5	Fan and pump motor	001.14	1
6	Fan	001.15	1
7	Capacitor	001.08	1
8	Adjustment bolt	001.16	1
9	Air cover set, lower	001.06	1
10	Air cover set, upper	001.06	1
11	Overload clutch	123.23	1
12	Fuel pump	012.29	1
13	Transformer base	012.35	1
14	Transformer	001.18	1
15	Automatic unit spacer	001.19	1
16	Automatic unit base	123.20	1
17	Siemens control unit	012.28	1
18	Reinforced supply fuel line	123.19	1
19	Reinforced return fuel line	123.19	1
20	Euro plug	123.18	1
21	Control relay set base	013.04	1
22	Control relay set	013.04	1
23	Thermostat grip	001.07	1
24	Control thermostat	123.01	1
25	Control thermostat	123.01	1
26	Safety thermostat	013.06	1
27	Burner compartment cover	001.20	1
28	Nozzle rod heater	001.04	1
29	Nozzle rod	001.03	1
30	Nozzle base	001.05	1
31	Nozzle round seal ring	123.21	1
32	Delavan fuel nozzle type 30609-05	123.05	1
32	Delavan fuel nozzle type 30609-07	123.07	1
32	Delavan fuel nozzle type 30609-11	123.11	1
33	Electrode and riser plate base unit	012.25	1
34	Ignition electrode	012.24	1
35	Electrode depresser	012.26	1
36	Photocell	012.34	1
37	Photocell clamp	012.27	1
38	Riser plate	001.01	1
39	Flame pipe seal	001.17	1
40	Flame pipe	001.21	1
41	Nozzle bar angular connector 1/4"	013.16	1
42	HV cable set	001.22	1
43	HV cable set	001.22	1
44	Patron heater	013.08	1
45	Housing support	001.23	1
46	Euro plug	123.22	1
47	Air reducer grip	123.12	1
48	Air pressure reducer	123.04	1
49	Air connector DN 7.2	013.14	1
50	Straight connector nipple 1/4" x 1/8"	123.16	1
51	Solenoid valve	123.02	1
52	Solenoid valve power supply	123.03	1
53	Air manometer	123.10	1
54	Air angular connector	123.15	3
55	Air tube	001.24	1
56	Distribution tank	013.02	1
57	Floater sensor	013.09	2
58	Main heater	013.07	1
59	Distribution tank cover	013.15	1
60	Fuel supply line	001.25	1
61	Fuel supply line	001.26	1
62	Burner housing	001.27	1
63	Fuel pump solenoid valve	001.28	1