



COMBINED WOOD AND PELLET BOILER

ECOTWIN

INSTALLATION AND USER MANUAL



VERSION: 2.1
UPDATE: 18.01.2019

Contents

1. GENERAL INFORMATION	3
1.1. Proper use of the appliance	3
1.2. Safety warnings	3
1.3. Data label	3
1.4. Document information	3
2. TECHNICAL FEATURES AND DIMENSIONS	4
2.1. Technical features	4
2.2. Function principle	4
2.3. Dimensions	5
2.4. Technical data	6
2.5. Fuel	7
3. BOILER MOUNTING	9
3.1. Transportation and delivery	9
3.2. Boiler room	9
3.3. Chimney	10
3.4. Mounting the additional door kit (optional)	12
3.5. Mounting the burner	14
4. INSTALLATION	15
4.1. Hydraulic connections	15
4.2. Return temperature protection	15
4.3. Filling the system	16
4.4. Chain thermostat installation	16
4.5. Connection diagrams	17
5. ELECTRICAL CONNECTIONS	18
5.1. General instructions	18
5.2. Electrical connection diagram	18
6. CONTROLLER	19
6.1. General description	19
6.2. Description of buttons	19
6.3. Operation functions	20
6.4. Menu parameters	21
7. BOILER START-UP	23
7.1. Initial lighting checks	23
7.2. Start-up with wood	23
7.3. Start-up with pellet	23
7.4. Pellet loading	23
7.5. Feeder filling procedure	24
7.6. Checks to carry after initial start-up	24
7.7. Operation mode	25
7.8. Chimney damper adjustment	26
8. SERVICE AND MAINTENANCE	27
8.1. Cleaning the boiler	27
8.2. Cleaning the chimney box	28
8.3. Cleaning burner's chamber	28
8.4. Maintenance intervals	28
8.5. Basic service procedures	29
8.6. Maintenance after long stop	29
9. TROUBLESHOOTING	31
CE DECLARATION OF CONFORMITY	32

1. GENERAL INFORMATION

1.1. Proper use of the appliance

Before you make use of this appliance make sure you have read and fully understood the instructions included in this manual.

The installation and use of the appliance must be performed according to the instructions indicated in this manual in combination with the current national safety regulations.

The appliance is designed for use in pumped hot water central heating systems. Any other use is considered improper and is prohibited. THERMOSTAHL ROMANIA declines any responsibility for damages or injuries caused by improper use; in this case the risk is completely at the user's responsibility.

To ensure an efficient and flawless function of the appliance, it is strongly recommended that you have performed an annual service by a qualified technician.

1.2. Safety warnings

All installation and maintenance procedures must be carried out by professional and authorized personnel, in compliance with the indications in the present manual and national regulations. Any failure to correctly install this appliance could cause damage or injuries!

Do not make modifications to parts of the appliance, unless you have contacted the company and an authorized service contractor.

Only original accessories and spare parts must be used to ensure correct and safe function.

Make sure you respect the cleaning and maintenance procedures on the corresponding intervals. Failure to do so can cause malfunction to the appliance and possible damages.

The boiler is design to function on the fuels indicated in the corresponding paragraph. Any other fuel is prohibited. Do not use explosive or flammable substances! Do not store such substances inside the boiler room.

The working pressure varies according to the model. Make sure you use the appropriate water pressure.



Working in a pressure higher than the one indicated in this manual is strictly prohibited and dangerous!

1.3. Data label

The data label of the appliance is placed on the boiler's side cover, on the external part. Make sure that it is properly placed and readable.

On the label it is indicated the serial number and the manufacturing year of the appliance.

1.4. Document information

This document is an integral and indispensable part of the product and must be retained in good condition by the user. Keep it in a safe place for future reference.

If the appliance is sold or transferred to another person, this manual has to always follow the appliance and handed to the new user or installer.

2. TECHNICAL FEATURES AND DIMENSIONS

2.1. Technical features

The ECOTWIN boiler series is designed for manual function on solid fuel: wood, agricultural residues, briquettes, with a minimum diameter of 15mm, and also wood pellet of 6-8mm diameter automatically by means of an automatic pellet burner. The boiler is equipped with two doors: one upper for cleaning of the heat exchanger and a lower door fuel loading and ash removal. The wood combustion is performed by an air door and a chain thermostat regulator.

The boiler is made of steel, ideal material for thermal fluctuations, resistant to expansion and contraction. Monobloc construction, with no other welded structures is an advantage of ECOTWIN boiler. Also this boiler is protected against thermal shock.

The boiler body is designed so that all surfaces that are in contact with the flame are cooled by water, including the grate where the ash and combustion residues fall. The two gas passes at the top, the large number of flue pipes, large volume of the furnace and boiler water as well, and symmetrical construction causes a high yield.

DESCRIPTION OF COMPONENTS

- Steel boiler body with heat exchanger
- Removable rear smoke box with inspection cleaning door
- Upper door for cleaning the heat exchanger
- Lower door with flange for pellet burner mounting
- Lower door with air door for manual wood function (optional)
- Ash box positioned on the lower part of the fire chamber
- Glasswool body insulation of 50 mm thickness
- Electrostatically painted external covers
- Chain thermostat regulator for wood combustion
- Automatic pellet burner with feeder
- Fuel tank

2.2. Function principle

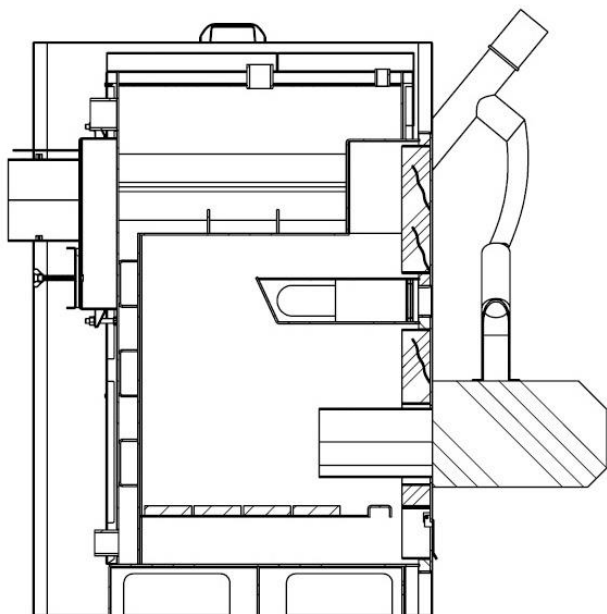

Fig 2. Boiler function

The function of the boiler is based on natural gas evacuation through the chimney. The lower door is equipped with flange for mounting a pellet burner and air door.

Alternative function on wood can be realized by unmounting the burner, and mounting the blind flange in place, and connecting the chain regulator to the air door.

With the optional kit which includes the second lower door, altering between pellet and wood can be performed easily by closing the corresponding door.

On manual mode with wood, the fuel is positioned on the grate. The pellet combustion is controlled by the automatic pellet burner.

The combustion takes place in the fire chamber. During the combustion the flame comes in contact with the side walls of the fire chamber, which are surrounded by water. The exhaust gases are guided through the heat exchanger to the smoke box, and afterwards evacuated to the chimney.

TECHNICAL FEATURES AND DIMENSIONS

2.3. Dimensions

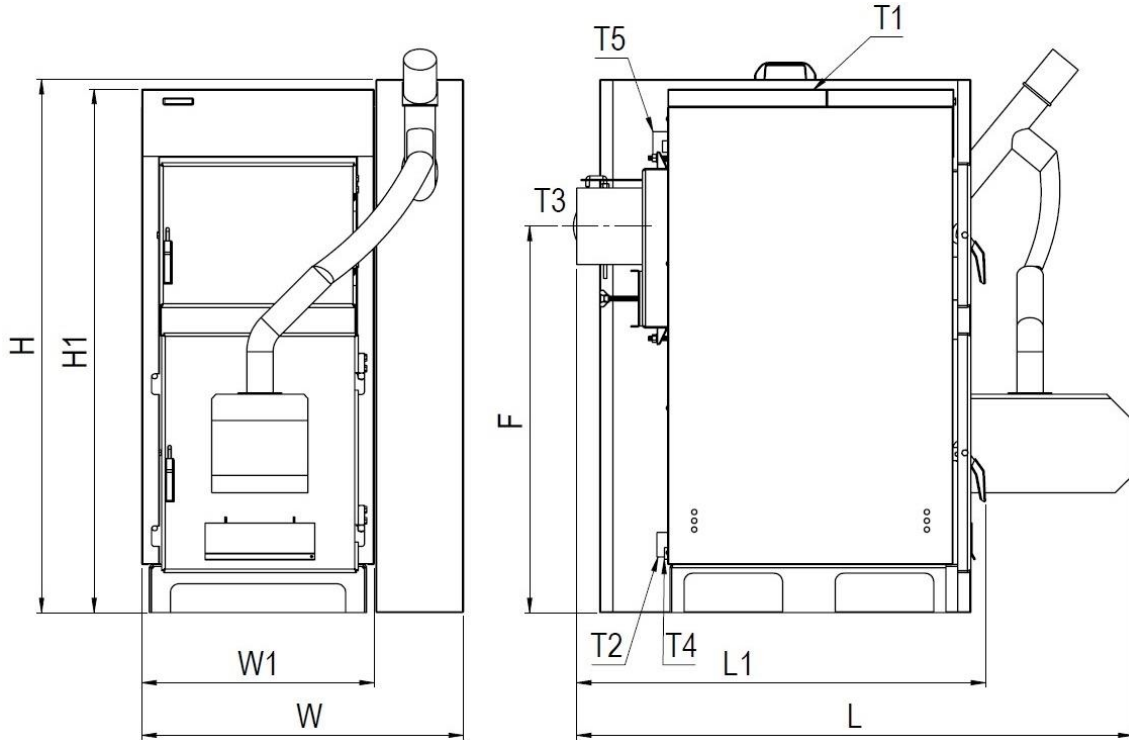

Boiler type	Wood loading dimensions	H	H1	W			F	L1	L
				SLIM	MID	MAX			
				mm					
ECT 25	340x385	1220	1195	735	885	1035	880	935	1270
ECT 30	340x385	1220	1195	735	885	1035	880	1035	1370
ECT 40	340x385	1220	1195	735	885	1035	880	1135	1470
ECT 50	465x425	1220	1310	865	1015	1165	1000	1035	1350
ECT 60	465x425	1220	1310	865	1015	1165	1000	1135	1450
ECT 80	565x510	1220	1650	990	1140	1290	1195	1385	1735
ECT 100	565x510	1220	1650	990	1140	1290	1195	1585	1935

Boiler type	T1-T2	T3	T4	T5
	inch	mm	inch	
ECT 25	1½"	Ø180	¾"	2"
ECT 30	1½"	Ø180	¾"	2"
ECT 40	1½"	Ø180	¾"	2"
ECT 50	1½"	Ø180	¾"	2"
ECT 60	1½"	Ø180	¾"	2"
ECT 80	2"	Ø200	¾"	2 ½"
ECT 100	2"	Ø200	¾"	2 ½"

TECHNICAL FEATURES AND DIMENSIONS

2.4. Technical data

Boiler type		ECT 25	ECT 30	ECT 40	ECT 50	ECT 60	ECT 80	ECT 100
Nominal power pellet / wood	<i>kW</i>	25/25	30/30	40/40	50/50	60/60	80/80	80/100
Furnace power	<i>kW</i>	27	33	44	55	66	88	110
Efficiency pellet / wood	%	91 / 83						
Boiler class ²		5						
Max working pressure	<i>bar</i>	3						
Test pressure	<i>bar</i>	4,5						
Max working temperature	°C	90						
Exhaust gas temperature	°C	180-220						
Fuel consumption at max work ³	<i>kg/h</i>	5,51	6,73	7,14	11,22	12,25	16,32	16,32
Water pressure drop (ΔT 20K)	<i>mbar</i>	20	24	32	48	52	60	64
Water contents	<i>l</i>	100	120	130	170	190	370	440
Fire chamber length	<i>mm</i>	480	580	680	580	680	850	1050
Weight (empty)	<i>kg</i>	298	325	352	402	423	735	825
Total power consumption (without optionals)	<i>kW</i>	0,49	0,49	0,49	0,55	0,55	0,60	0,60
Electrical connection	<i>V/Hz</i>	230 / 50						

1. Nominal power output is obtained with fuel type C, calorific power 4,9 kWh/kg according to standard EN 303-5:2012.
2. According to standard EN 303-5:2012, for fuel type C (wood pellets).
3. The values are calculated for fuel type C, calorific power 4,9 kWh/kg according to standard EN 303-5:2012.

2.5. Fuel

2.5.1. Wood

The ECOTWIN series is designed for use with solid fuel of biogenic or fossil nature. This means different types of natural wood, solid residues of organic nature coming from trees or agricultural plants, wood briquettes of various types.

Good quality wood is oak, ash, beech, maple, olive tree and fruit trees, except cherry. Medium quality wood is chestnut and birch. Low quality wood is poplar and willow.

The nominal characteristics of the boiler are calculated for use on wood!

Fuel		Calorific power	
		kWh/kg	kcal/kg
Oak		4,2	3.600
Beech		4,0	3.450
Birch		4,3	3.700
Poplar		4,1	3.500
Pine		4,4	3.800
Spruce, Fir		4,5	3.900
Wood briquettes		4,0 - 4,9	3.600 - 4.200
Carbon	Anthracite	5,6 - 6,5	4.800 - 5.600
	Coal	4,5 - 6,4	3.900 - 5.500
	Brown carbon	2,7 - 4,2	2.300 - 3.600
	Lignite	1,6 - 3,8	1.400 - 3.300

Table 1. Calorific power of different types of wood

Every type of wood contains a significant amount of humidity, which highly affects its combustion behavior and calorific value. Boiler output, efficiency and autonomy will significantly diminish as the humidity increases. The nominal data presented in this manual are calculated for humidity content 15%.

For proper and efficient function and a long lifespan, it is strictly recommended that only dry wood is used, with a humidity content of 15%. Practically, this means at least one year dry wood. Maximum humidity content allowed is 25%.

As understood, wood is an extremely heterogeneous fuel, due to different essences, different humidity contents, shapes and dimensions. This is why the combustion behavior highly varies through time and average data as fuel consumption, autonomy, and output are very difficult to forecast.

Calorific power in relation to humidity

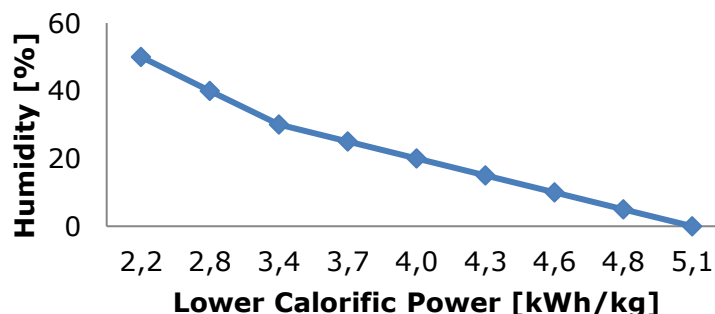

It is prohibited the use of laminated wood, or other chemically treated wood. It is prohibited the use of explosive, inflammable materials, plastic, domestic residues, etc.

2.5.2. Pellet

Pellet is used in an automatic way by means of an automatic pellet burner. Only wood pellets are to be used with this burner. No other fuel is allowed be used in the burner. The pellet is deposited in the fuel tank and then automatically fed through the feeder, which is controlled by the burner.

As fuel, it is recommended to use only premium quality wood pellet 6-8 mm diameter. Pellet of lower quality or agropellets can only be used if approved by the manufacturer. Note that if lower quality pellet is used, the ash produced can be significantly bigger and the cleaning interval more often.

Pellet fuel characteristics	
Diameter	6-8 mm
Length	12-30,5 mm
Density	650-700 kg/m ³
Ash content	<1%
Calorific power	>4,8 kWh/kg
Humidity content	<8%

Table 2. Pellet fuel characteristics



The quality of the pellets, calorific power, humidity and ash content is very important for the boiler function and efficiency!

Normally, if using pellets with low ash content (DIN+ quality certification) the burner needs cleaning once every week. If low quality pellets are used this might be needed up to once a day.



It is prohibited the use of processed wood pellets, or other chemical treatment.



It is prohibited the use of explosive, inflammable materials, plastic, domestic residues, etc.



NEVER BURN ANY TYPE OF CORN, CHERRY PITS, STICKS OR OTHER TYPES OF FUEL IN THE BURNER.

3. BOILER MOUNTING

3.1. Transportation and delivery

The boiler is delivered on wood pallet, well positioned with metal plates. Remove them carefully by unscrewing the screws holding them in place.

The loading and unloading of the boiler must be performed with a forklift or a crane.



The boiler is very heavy. Do not try to lift by hands or other unsuitable equipment. Danger of injury! Perform all moves with extreme caution.

Remove the boiler packaging with attention. **Keep the packaging material away from children since it can be dangerous.** After having unpacked everything, make sure that the appliance is intact and undamaged. In case of doubt do not use the appliance and inform the supplier.

The ECOTWIN boiler is delivered with the following equipment:

- Boiler steel body
- Rockwool insulation mounted on the boiler body
- Metal covers mounted on the boiler body
- Pellet burner
- Fuel feeder
- Fuel tank
- Ash box
- Cleaning tools
- Chain regulator
- A second door for alternative wood combustion (optional)

In the documentation folder you will find:

- Technical manual
- Warranty leaflet
- Declaration of conformity

3.2. Boiler room

3.2.1. General requirements

The boiler must be installed in a special and separate room. This room must be chosen so that it offers easy access for fuel transport, air supply and exhaust gas evacuation. The doors of the boiler room must be metallic, open outwards, and have at least 0,9 m width.



The boiler installation is prohibited in rooms with extensive dust, dangerous gases, and moist spaces.

For the correct boiler function it is necessary that the boiler room has openings for natural ventilation and combustion air supply. It is recommended that two different openings are used for this purpose, positioned on opposite walls and diagonally to ensure good air circulation. The total surface of the openings must be at least 1/12 of the boiler room surface. Forced ventilation is prohibited in the boiler room.

The boiler room must be provided with a drainage channel. All safety devices must be connected to this channel.

The boiler room must have an appropriate fire extinguishing system, according to the regulations in force. In case that the building is designed with a fire alarm system, a smoke detector must be positioned on top of every boiler.

The fuel storage is prohibited in the boiler room. If so, the storage must be separated from the boiler with a non-flammable wall, and proper distanced from the boiler.

3.2.2. Boiler room dimensions

The boiler must be placed on a horizontal plane, with adequate mechanical resistance to support the boiler's weight. The boiler must be positioned in the room in such a way so that it is easily accessible from all the sides. The following dimensions are recommended (see Fig 2):

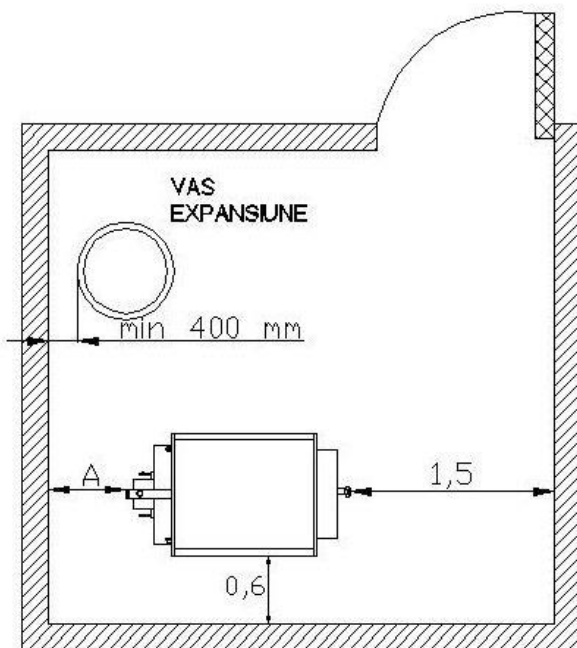

Fig 2. Boiler room dimensions

The distance between the boiler and the back wall - is the proper distance that allows easy access for inspection and maintenance.

The distance between the boiler and side wall - at least 0.6 m.

The height of the boiler room - at least 2 m.

Access and service spaces of boiler room and hall doors paths will always be free.

In the boiler room will be displayed operating instructions, taking into account the specificities of the boilers mounted. Also, you will see internal instructions of staff and service duties.

3.3. Chimney

The chimney installation must supply sufficient draught, air tightness and protection against condensation.



The appropriate chimney installation is very important for the boiler's efficient and safe function!

The chimney must be positioned if possible in the interior of the building. It must be vertical, with no changes in the direction. The cross-section of the chimney can be round or rectangular. If the chimney is installed in the exterior, it must be insulated.

The horizontal part connecting the boiler's chimney pipe with the vertical chimney must have maximum length 2 m. If this distance is bigger, it is recommended to have a 15-30° inclination upwards. The connection with the boiler's chimney pipe must be air-tight.

The chimney must be equipped with a cleaning door at its base. Also cleaning doors are recommended where there are changes in direction and ash can be accumulated. Tactical cleaning is recommended (every 3 months) for efficient boiler function.

A chimney terminal must be installed at the end of the chimney for protection against weather effects and foreign objects entrance. In areas with strong winds a special anti-downdraught terminal is recommended.

The chimney height must exceed the roofline by at least 1 m. If there are other obstacles positioned on the roof, the chimney height must exceed them by at least 1 m. If there are multiple chimneys, minimum distance between them is 0,3m.

INSTALLATION

Each boiler should be connected to an independent chimney. Connection of multiple boilers to the same chimney is not recommended.

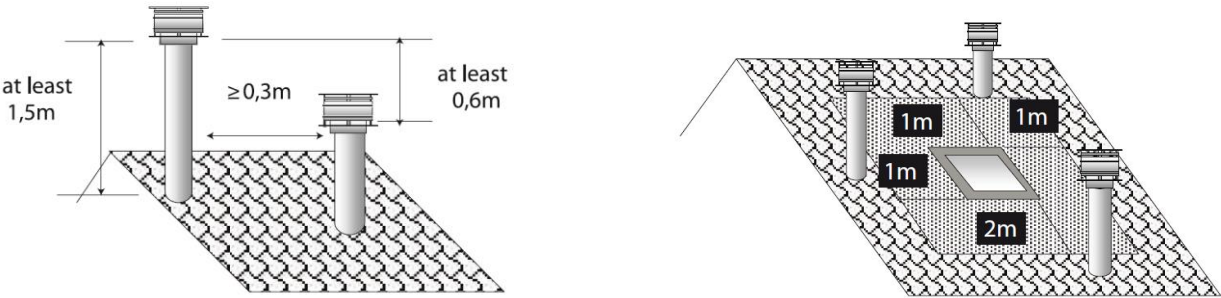

Fig 3. Chimney distances

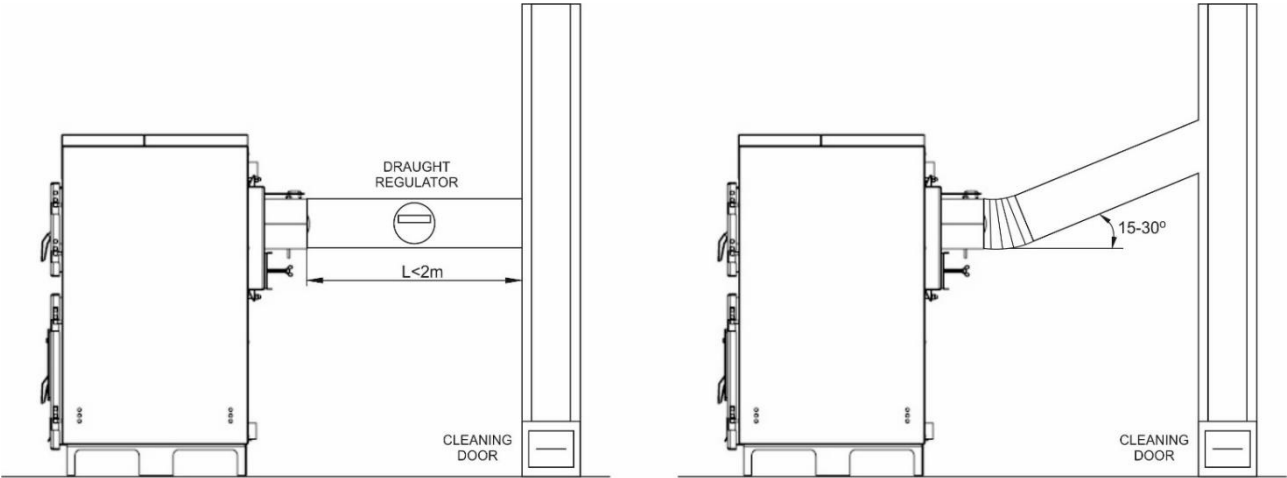

Fig 4. Chimney connection

3.4. Mounting the additional door kit (optional)

With the optional kit which includes the second door, altering between fuels is performed just by closing the corresponding door.

To install the second door follow the next steps:

- Remove the side cover
- Instal the hinge screw on the front plate of the boiler according to drawing with fixing nut and tightening nut and fix tightly
- Place the door into position by introducing the hing pin in the hole of the hinge screw mounted before
- Close the door and make necessary adjustments for door air-tightness

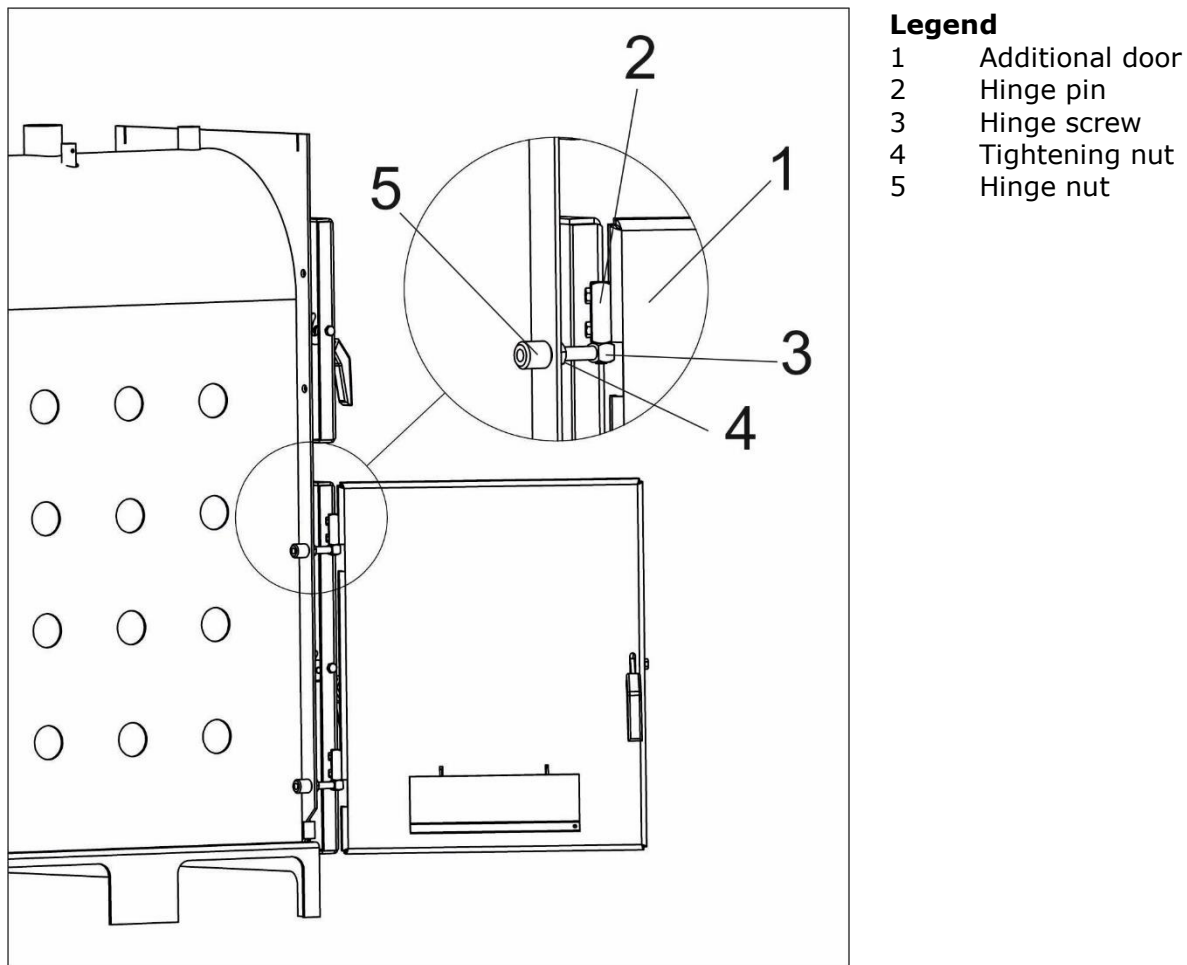

Fig 5. Mounting the additional door

INSTALLATION

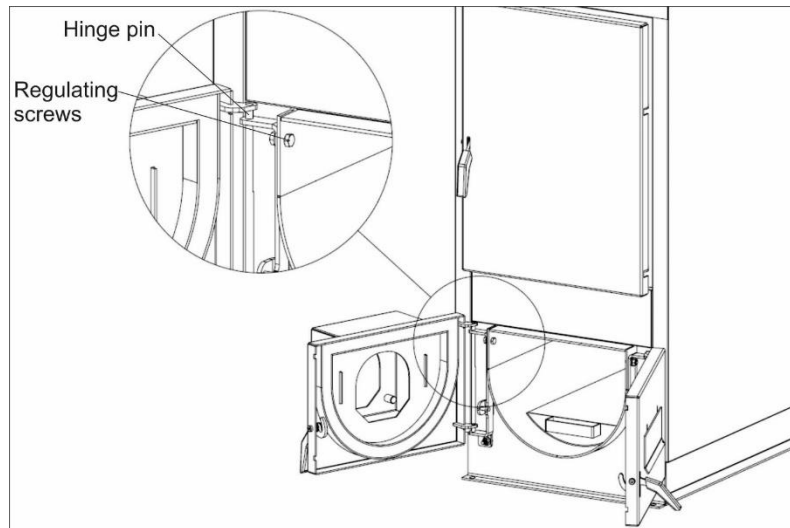
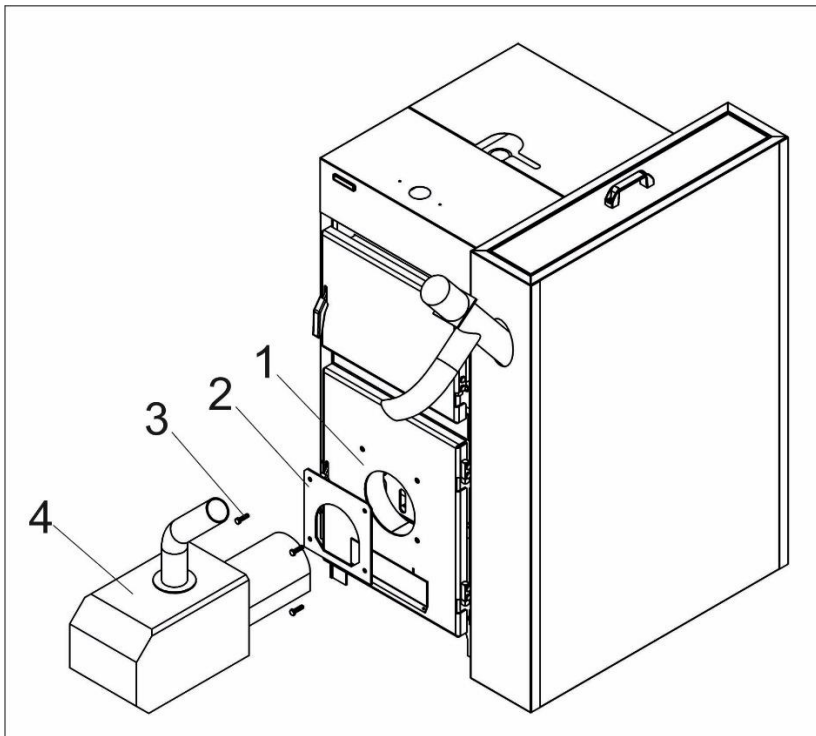

Fig 6. Mounting the two doors

3.5. Mounting the burner

The burner is mounted on the lower door flange. First mount the insulation gasket and then the burner with the four screws included, like in **Error! Reference source not found.**. Make sure that the burner tube is correctly positioned inside the fire chamber, and the door opens normally.



Legend

- 1 Burner mounting flange
- 2 Burner gasket
- 3 Fixing screws
- 4 Pellet burner

Fig 7. Mounting the burner

The pellet silo must be positioned normally from the right side of the boiler, so that the door opens easily. It must be positioned as close to the boiler as possible so that the feeder length will be sufficient.

The pellet feeder must be inserted in the silo before you fill it with pellets. The feeder must be positioned with inclination, optimum at 30-45° to the floor. **The pellet feeder cannot be positioned at angle more than 45°, nor vertically or horizontally!** After positioning secure it so that it doesn't move. The connection between the pellet feeder and the burner is done by a flexible hose. This hose must also have an inclination and be tightened so that it allows free fall of the pellets towards the burner. The connection of the hose with the burner and the feeder must be air-tight. Use the tighteners provided.



The positioning of the pellet feeder and the silo are very important to the burner's operation! If not positioned correctly it can cause malfunction and stop of the burner.

4. INSTALLATION

4.1. Hydraulic connections

The boiler is intended for connection with an open expansion vessel network. The boiler can be connected also with closed expansion vessel, if it is equipped with an overheating serpentine (optional).

The boiler is intended for maximum working temperature 90°C and maximum pressure 3 bars. When connected with a closed expansion vessel, its volume must be chosen double to a similar installation on liquid or gas fuel.



If a connection pipe is not used, it must be sealed before water fill!

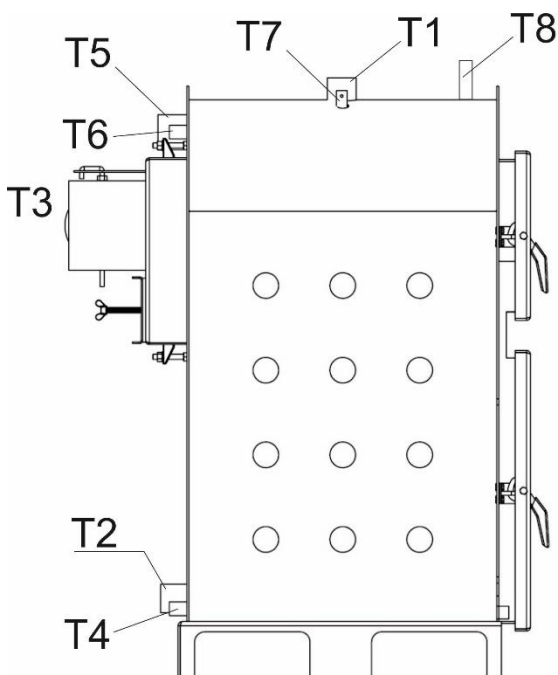

Legend

- T1 Outlet
- T2 Return
- T3 Chimney pipe
- T4 Discharge connection
- T5 Safety heat exchanger connection
- T6 Safety heat exchanger sensor bulb connection
- T7 Boiler sensors bulb
- T8 Chain regulator connection

4.2. Return temperature protection

For the correct function of the boiler and for protection against corrosion it is very important to ensure steady temperature at the return of the boiler of at least 55°C.

This can be ensured by installing a recirculation pump between the boiler outlet and return (see connection diagrams).

An alternative variation is by installing at the return of the boiler a three-way thermostatic valve.



Having a return temperature less than 55°C is very dangerous for the boiler long-life and can cause warranty loss!

4.3. Filling the system

After completing all the hydraulic connections, the circuit may be filled with water. After filling the system, open the radiators air valves to get rid of the air in the installation.

Verify that the installation pressure is according to the technical feature of the boiler. The pressure must be verified through the boiler's manometer. An additional manometer should be installed on the cold water inlet to verify the cold pressure, at the lowest point of the installation, at a point close to the boiler.

The whole installation must remain under nominal pressure for at least 10 minutes. During this period, check that all the connections are tight and there are no water leakages. Make sure that during this period no pressure drop appears.

After firing the boiler, make sure the network functions properly at working temperature and pressure.



The hardness of the mains water supply affects the boiler's life span. It is recommended to use a water softener if water hardness exceeds 15°f.



Do not fill the system at the working pressure! When the boiler will be heated, the water pressure will raise. Filling pressure must be at least 1 bar lower than working pressure!

4.4. Chain thermostat installation

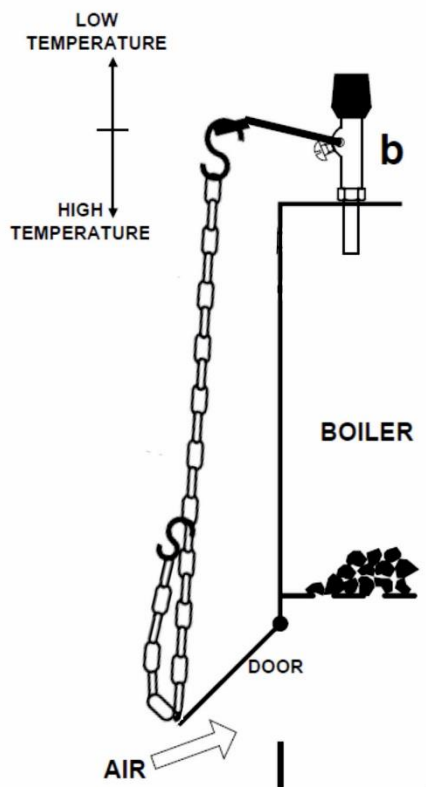

ECOTWIN boiler is equipped with air door on the lower part and is delivered with chain thermostatic regulator.

Install the regulator at the connection pipe on the upper side of the boiler and pass the chain through the hook provided on the air door.

Choose the desired boiler temperature from the thermostat head (red scale is valid).

The thermostatic regulator controls the boiler temperature by controlling the supply of combustion air. The chain length must be adjusted so that when the set temperature is reached the air door is in closed position and no air is supplied.

4.5. Connection diagrams

4.5.1. Open expansion vessel connection

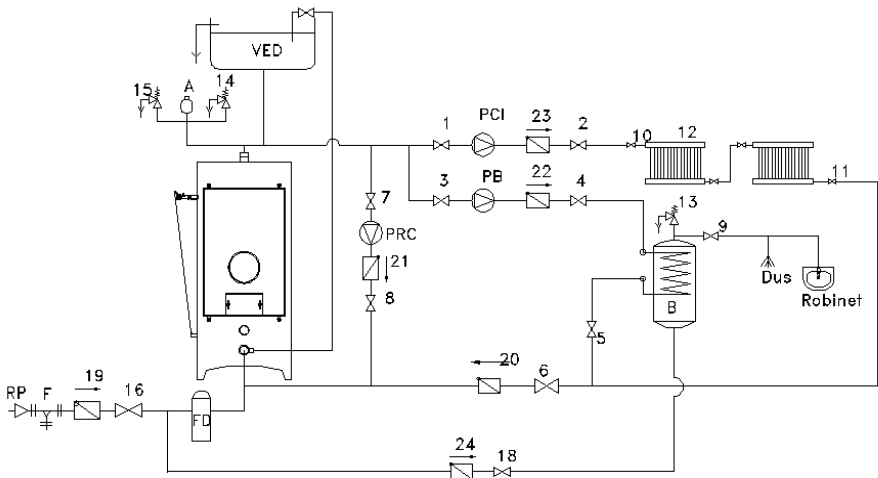

Legend

- | | | | |
|--------|-------------------|-----|-----------------------|
| 1-9. | Separation valves | B | Hot water boiler |
| 10,11. | Radiator valves | VED | Open expansion vessel |
| 12. | Radiators | PCI | Central heating pump |
| 13-15. | Safety valves | PRC | Recirculation pump |
| 16. | Filling valve | RP | Pressure reducer |
| 17. | Drainage valve | F | Filter |
| 18. | Cold water valve | A | Air relief valve |
| 19-24. | One-way valves | FD | Water softener |

4.5.2. Closed expansion vessel connection

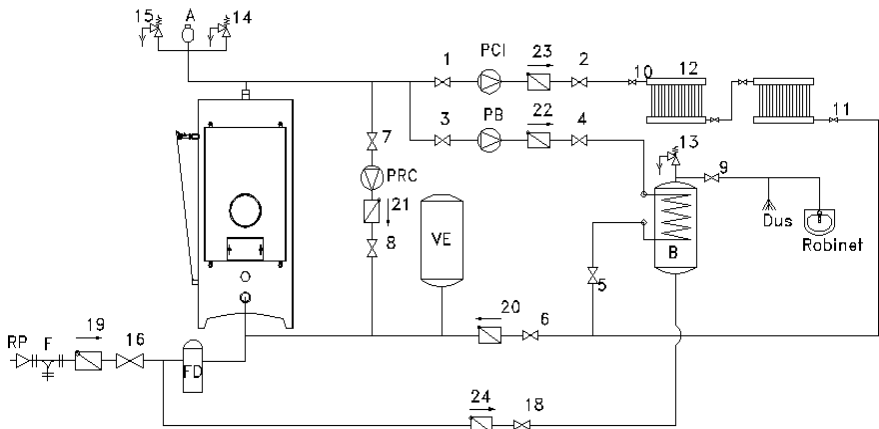

Legend

- | | | | |
|--------|-------------------|-----|-------------------------|
| 1-9. | Separation valves | B | Hot water boiler |
| 10,11. | Radiator valves | VE | Closed expansion vessel |
| 12. | Radiators | PCI | Central heating pump |
| 13-15. | Safety valves | PRC | Recirculation pump |
| 16. | Filling valve | RP | Pressure reducer |
| 17. | Drainage valve | F | Filter |
| 18. | Cold water valve | A | Air relief valve |
| 19-24. | One-way valves | FD | Water softener |

5. ELECTRICAL CONNECTIONS

5.1. General instructions

All electrical connection must be performed by an authorized professional, in conformity with the local regulations and the indications of this manual. Connections must be done according to norms EN 60529 and EN 60335-1, and protection norms IP 40 and IP 44.

All wiring must be waterproof insulated. Exposed cables should be protected within plastic channel. The main electrical supply of the boiler must be connected to an independent safety of max 16A. The boiler room lighting must be on a separate circuit.

The user is obliged to connect the boiler to an efficient grounding system.



THERMOSTAHL ROMANIA SRL declines any liability for damage caused to people, animals and goods, due to defects caused by faulty electrical connections or lack of connecting the boiler to an efficient grounding system.

5.2. Electrical connection diagram

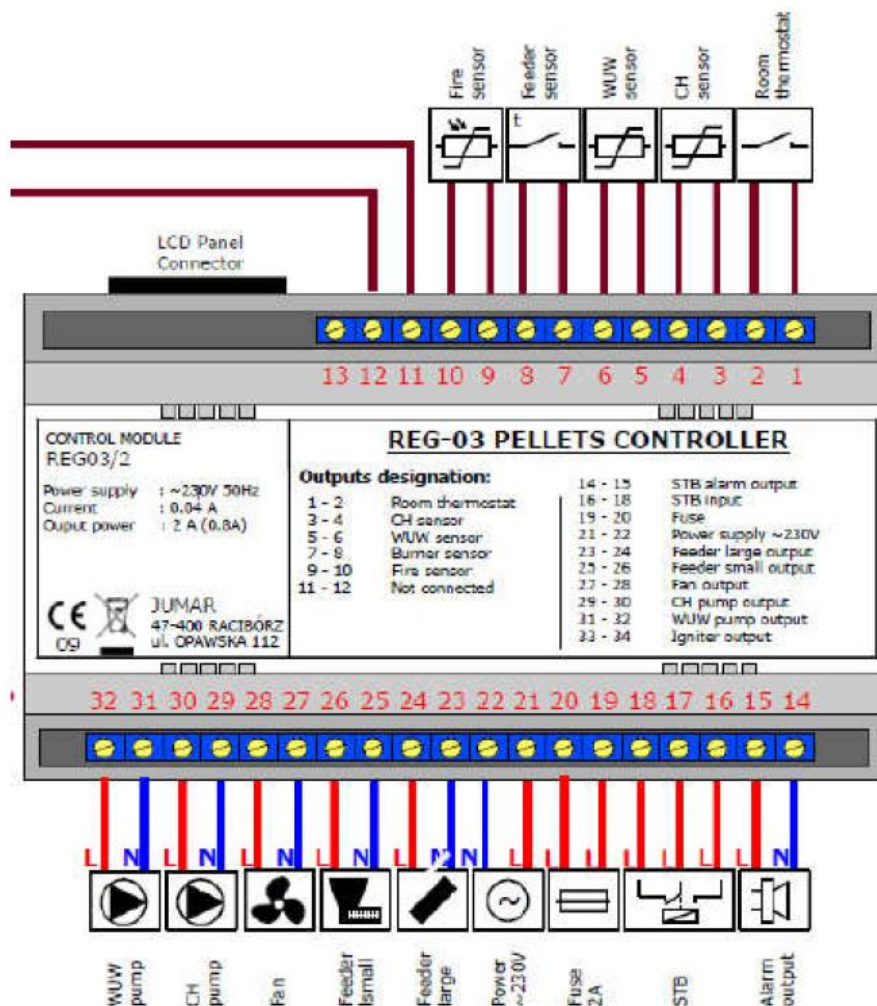

Do not connect the pumps to the controller, because when the burner will be stopped on manual mode, they will not function!

6. CONTROLLER



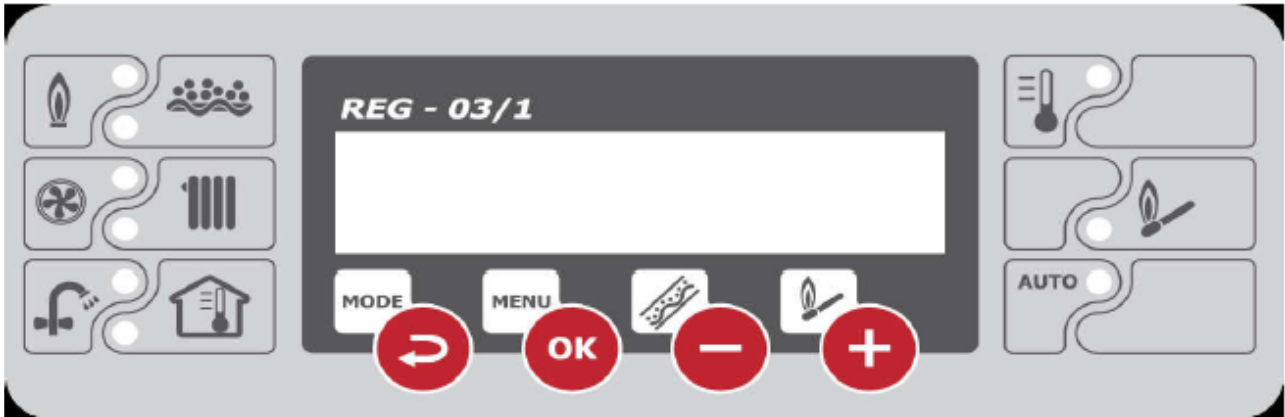

6.1. General description



Description:

- Diodes signaling the status of outputs and the working mode of the driver,
- LCD screen used for communication between the device and the user,
- Buttons steering the driver's work.

6.2. Description of buttons

Button	Function	
	1	Changes the burner's working mode - "STOP" , "IGNITION" , "AUTOMATIC WORK" .
	2	Return to the previous menu
	1	Entry on the Menu's parameters
	2	Saves the change of a parameter
	1	In the Ignition MODE activates the feeder for the time specified on the parameter "Filling Feeder Time"
	2	Go to the previous menu or parameter Decreases the value of a parameter
	1	In the Ignition MODE activates the ignition procedure
	2	Go to the menu or parameter Increases the value of a parameter του καυστήρα.

6.3. Operation functions

After switching the burner on, it is appeared on the LCD screen the program's logo defining the type of the driver and the version of the current software

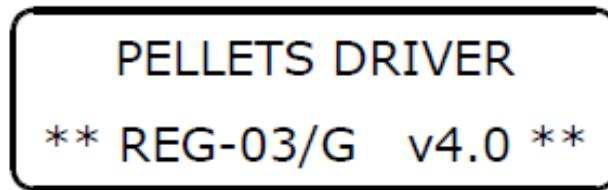

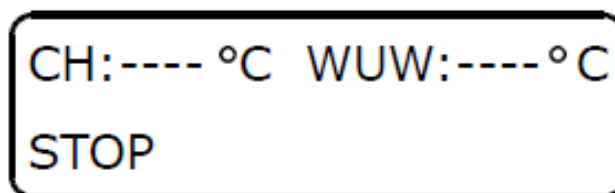

While activating, the burner carries out a test of the connected sensors. In case of one lacking, on the screen appears an appropriate message (---). The work of the burner without a heating water temperature sensor (CH) is blocked and an emergency mode is activated (CH pump is still on).

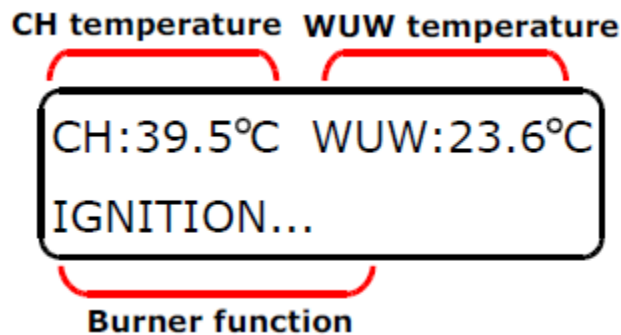

Correct connection of sensors causes displaying of actual CH furnace's temperature and the temperature of useful warm water of the WUW buffer (if the function is active). On the screen appears which function is currently used by the driver.



The burner may work in three working modes ("STOP", "IGNITION", "AUTOMATIC WORK"). The mode changes when the "MODE/  button is pressed. Activating the "STOP" mode is possible in all modes after pressing the "MODE/  button for 3 seconds. When Stop is activated, the burner goes at "Burning off" process (if there is fire) and the at "Cleaning" process.

When the burner is activated for first time, it is on "Stop" mode. Every next time, its status is saved in the regulator's non-volatile memory. Activating the driver again, automatically causes switching on of the lately used working mode.

In the table beneath a short description of particular functions of the burner, activated depending on the working mode of the driver, is shown.

CONTROLLER

FUNCTION'S NAME	DESCRIPTION OF FUNCTIONS
STOP	Burner stopped.
FEEDER FILLING	Filling the feeder. Filling stops automatically after about 10 minutes.
IGNITION	The burner is on Ignition process, which mean that has fed with ignition dose of pellet, the heating element (igniter) and the air fan are working. The mode would be automatically changed after detecting a flame by the sensor.
CLEANING	The air fan works at full speed for one minute, to remove the remaining ashes from the burner's fire chamber. This function takes place also at the first minute of ignition
WORK	Heating the boiler up to the set temperature. Showing the actual power of the burner.
MAINTAIN	Sustaining the set temperature (if the burner's working mode is in the mode of continuous work)
BURNING OFF	Putting off the burner. Active in the "STOP" mode or in the temporal working mode of the burner.
STANDBY	Standby of the burner for the decline of the temperature of a hysteresis (if the burner's working mode is in the temporal mode).

6.4. Menu parameters

To move round the menu and to set particular parameters there are four buttons placed on the driver's panel: **"MODE/⏏"**, **"MENU/OK"**, **"+"**, **"-"**. The parameters chosen by the user are divided into four groups: (A) **"CH FURNACE SETTINGS"**, (B) **"WUW BUFFER SETTINGS"**, (C) **"BURNER SETTINGS"**, (D) **"DRIVER SETTINGS"**. The division of particular parameters in groups is shown in the **"Settings table"**.

CH FURNACE SETTINGS (A)

FUNCTION NO.	FUNCTION NAME	SETTING UNIT	SETTING RANGE	MANUFACTURER SETTING
1	HEATING WATER TEMPERATURE	°C	35 - 85	65*
2	CH PUMP ACTIVATION TEMPERATURE	°C	20 - 60	35*
3	CH FURNACE HYSTERESIS	°C	1 - 20	5*
4	FURNACE MODE	---	Winter/Summer	Winter*

WUW BUFFER SETTINGS (B)

FUNCTION NO.	FUNCTION NAME	SETTING UNIT	SETTING RANGE	MANUFACTURER SETTING
1	WUW BUFFER TEMPERATUR	°C	20 - 80	40*
2	WUW SURPLUS TEMPERATURE	°C	5 - 20	10*
3	WUW PRIORITY	---	Yes/No	No*

CONTROLLER

BURNER SETTINGS (C)

FUNCTION NO.	FUNCTION NAME	SETTING UNIT	SETTING RANGE	MANUFACTURER SETTING
1	BURNER POWER (WORK)	kW	10 - 80	30*
2	BURNER POWER (MAINTAIN)	kW	2- 9	3*
3	BURNER MODE**	---	Continuous/ Single/Analogue	Continuous*
4	SELF CLEANING FREQUENCY TIME	Min	10-480	240
5	SELF CLEANING TIME	sec	0-60	0
6	BURNER FLAME MEASUREMENT	%	0-100	-----

**** Burner has 3 modes: continuous mode, single mode and analogue mode.**

Single mode: The burner reaches the desired "HEATING WATER TEMPERATURE" and burns off. Then, it starts its operation again when the temperature of the boiler goes down to the temperature "HEATING WATER TEMPERATURE - CH FURNACE HYSTERESIS". The CH FURNACE HYSTERESIS must be more than 10°C.

Continuous mode: The burner reaches the desired "HEATING WATER TEMPERATURE" and goes down at 3kW (maintain). When the boiler's temperature goes down to the temperature "HEATING WATER TEMPERATURE - CH FURNACE HYSTERESIS", the burner increases its power from 3kW (maintain) to the maximum burner power (i.e.30kW). The CH FURNACE HYSTERESIS must be no more than 5°C.

Analogue mode: The burner reduces its power 1/3 (for example: from 30kW to 21kW) 10°C before the furnace reaches the "HEATING WATER TEMPERATURE". When the temperature of the furnace is 5°C before "HEATING WATER TEMPERATURE", the burner reduces its power again 1/3 (for example: from 21kW to 12kW).

DEVICE SETTINGS (D)

FUNCTION NO.	FUNCTION NAME	SETTING UNIT	SETTING RANGE	MANUFACTURER SETTING
1	LANGUAGE SETTINGS	---	Polish/ English/ German/Greek/ Serbian/Romanian	English*
2	FACTORY SETTINGS	---	Yes/No	---
3	ENABLE SERVICE MODE	---	000 - 999	---

7. BOILER START-UP

7.1. Initial lighting checks

Before you start the boiler, make the following checks:

- Check that all the hydraulic connections and make sure they are tight. Make sure there is no leakage or moisture on the pipes or other equipment.
- Make sure that the connection with the chimney is air-tight and the chimney installation is properly made.
- Check that the controller bulbs are well inserted and secured in the boiler's case.
- Make sure that the pressure in the network is correct.
- Check that the boiler pump and the central heating pumps function properly.
- Make sure that the connection with the expansion vessel is correct and the expansion volume is sufficient for the boiler. No valves should be installed between the boiler and the expansion vessel.
- Make sure the boiler's separation valves are open.
- Make sure that there is sufficient air supply and natural ventilation in the boiler room.



Do not store inflammable materials or fuel close to the boiler! Before you light the boiler make sure the boiler room is clear and safe.

7.2. Start-up with wood

To correctly start up the ECOWOOD boiler follow the next steps:

- Make sure the chain regulator is correctly installed and functional.
- Make sure the chimney damper is positioned in horizontal position (completely open).
- Open the lower door (fire chamber) and introduce a sufficient amount of small and thin pieces of wood.
- Using sheets of thin paper light the wood placed inside the boiler.
- Close the door of the boiler.
- Wait several minutes until the flame develops and produces some embeds.
- After formation of embeds, load the fire chamber with wood. Position them on top of the grate.
- Close the door and secure it with the handles.



It is prohibited to light the boiler with inflammable or explosive liquids.

7.3. Start-up with pellet

- Make sure that the flexible pipe is connected to the burner tube.
- Fill the fuel tank with pellets, perform the feeder filling procedure if the tank was empty.
- Make sure that the burner controller cable is connected, and the temperature sensor is introduced in the boiler bulb.
- Activate the burner from the general power switch.
- By pressing the "MOD" button once, the automatic burner function begins.

7.4. Pellet loading

The fuel must be loaded in the fuel tank from where it is then transferred automatically to the burner by means of the pellet feeder. The feeder is directly controlled by the pellet burner.

During first start-up of the burner, the feeder must be completely filled. This procedure can take up to 15 minutes, depending on the feeder length and the motor rotation speed.

When loading fuel to the tank, be careful so that no big wood pieces or plastic materials do not enter the tank. These objects can block the feeder or even damage it and cause failure of the pellet burner. Fuel can be added to the silo at any point of the boiler function.

Do not leave the tank to reach completely empty, because the feeder will empty and you will have to repeat the filling procedure.



Do not load fuel manually directly to the burner! The pellet loading must only be performed through the pellet feeder!

7.5. Feeder filling procedure

1. Remove the plastic tube connection the burner with the feeder
2. Burner must be at stop mode. So, "Stop" appears on the LCD scree
3. By pressing the button "**MODE/**  " once changes the operation from "**Stop**" to "**ignition**".
4. "**CHOICE FUNCTION-/+**" appears on the LCD screen



5. Press the button to start the feeder
6. Feeders operation lasts 11min (Manufacturer's setting / Feeder's filling time"



7. When the wood-pellet starts to come out of the feeder, press to stop the feeder
8. Connect the feeder with the burner, by using the plastic pipe.



9. If the "Feeder's filling time" is not enough, press to start the feeder again

7.6. Checks to carry after initial start-up

During the first start-up you need to carefully check the air-tightness of all the connections, especially the doors and the connection with the chimney.

Check that the thermostats function properly and devices operate accordingly. Wait for the boiler to reach the preset temperature and make sure the fan stops properly and the flame falls down.

Check the temperature and pressure rise in the network. Make sure it is according to the indications. Check if there is any water leakage in the network.



After burning of the fuel is completed, check the situation inside the boiler. If the walls are too black, it means that there is insufficient air supply. If there is condensation forming on the boiler walls, it means that the pump operation starts at a low temperature or the fuel has too big humidity content. Make sure you set the pump according to the indications and you install a return temperature protection system as indicated.

7.7. Operation mode

7.7.1. Starting the burner

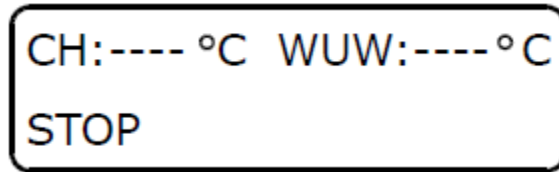
1. Activate the burner by connecting it with a power supply (230Volt, 50Hz)
2. It is written on the LCD screen the following _



3. By pressing the button "MODE/  " once changes the operation from "Stop" to "ignition".
By pressing the button "MODE/  " changes the operation from "Ignition" to "Automatic".
4. In "Automatic mode", starts the operation of the burner.

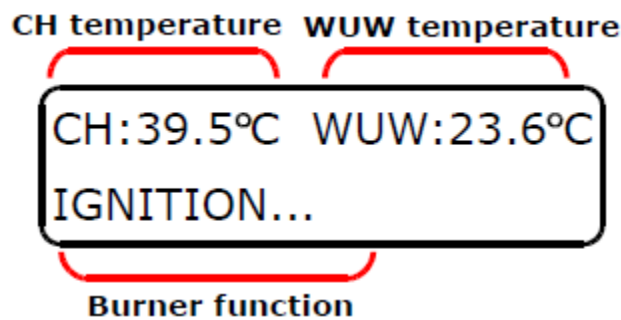

5. When the photo sensors detects fire, then the burner starts its "Work" by increasing its power gradually to the power it has been set (i.e 30kW)
6. When the boiler's water temperature reaches the desired temperature "HEATING WATER TEMPERATURE ", the the power of the burner goes down ta 3kW (**Maintain mode**)
7. The burner works at "Maintain mode" till the boiler's water temperature goes down to the temperature:

"HEATING WATER TEMPERATURE - CH FURNACE HYSTERESIS"

7.7.2. Stopping the burner

1. The burner can be either at "Work" or "Maintain" or "standby"
2. Press the button "MODE/  "continuously till "STOP MODE" appears on the screen.
3. It is written "Burning off" till the photo sensor stops to detect fire (3-5 min)
4. When the photo sensor stops to detect fire, "cleaning procedure takes place for few seconds.

7.7.3. Changing from pellet to wood

The boiler does not change automatically from one fuel to the other. **It is prohibited to use wood when the burner is installed on the boiler.** When using wood, remove the burner according to the instructions below:

1. Stop the burner function according to paragraph 7.7.2.
2. Wait for the burner to completely burn-off the pellets and enter in stop mode.

BOILER START-UP

3. Disconnect the burner from electricity, then remove the burner from the boiler flange.
4. Cover the flange with the flange cover provided.

In order to mount the burner follow the procedure inverse.



The use of wood and pellet at the same time is strictly prohibited!



Remove the burner before using wood! The use of wood when the burner is mounted on the boiler is prohibited!

7.8. Chimney damper adjustment

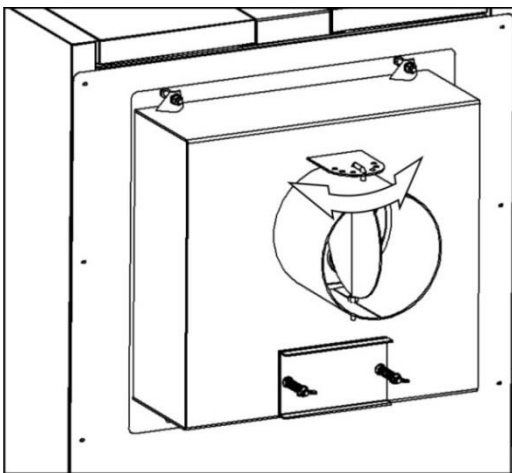

Fig 8. Chimney damper

The boiler chimney pipe is equipped with a damper. This can be set in various positions to throttle the exhaust gases.

At nominal function of the boiler this damper should be normally open. Also it should always be at open position at boiler start-up.

If the chimney draught is too big and the gases are evacuated too fast, set this damper at a side position by inserting the positioner at a different hole.

8. SERVICE AND MAINTENANCE

8.1. Cleaning the boiler

Solid fuel boiler require regular cleaning in order to function properly and efficient. **Cleaning must be effected at least once a week.** The boiler is equipped with three cleaning tools appropriate for the cleaning procedure of the boiler, as shown in Fig 9.

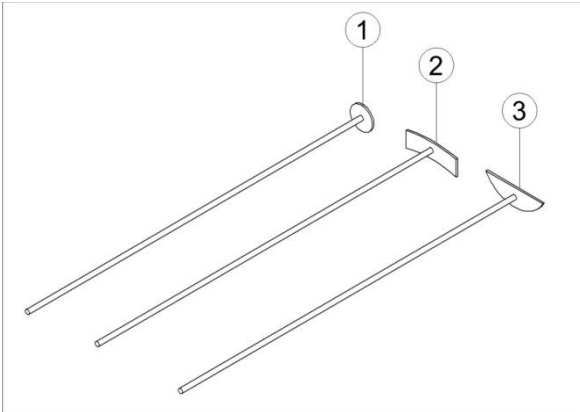

Legend:

1. Tubes cleaning tool
2. Heat exchanger cleaning tool
3. Ash cleaning tool

⚠ The boiler function must be stopped before cleaning! Make sure all the devices are stopped, and the boiler has cooled down. It is strictly prohibited to clean the boiler while in function!

Fig 9. Boiler cleaning tools

Open the upper door to have access to the heat exchanger. Remove the turbinators from the tubes, and clean the tubes with the appropriate tool. Afterwards clean the exterior surface of the cylindrical heat exchanger with the exchanger cleaning tool, as shown in Fig 10. With the same tool, scrape the ash and any other remains from the side walls of the boiler.

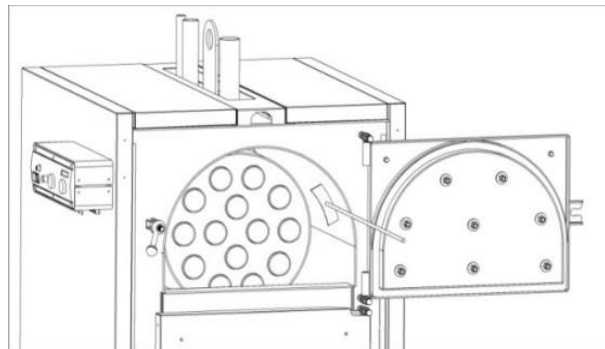
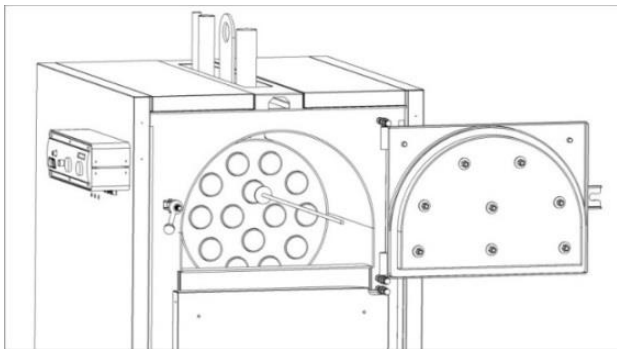
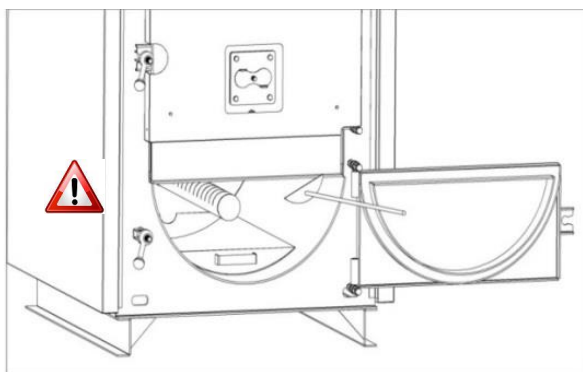

Fig 10. Cleaning of the heat exchanger



Open the lower door of the boiler and remove the ash box. Empty all the containing ash. With the ash cleaning tool you can scrape the lower surface of the boiler for any residues of ash.

The ash must be disposed in an appropriate container! Do not throw the ash together with the domestic garbage. Be careful since ash might contain hot particles, even long time after stop.

Fig 11. Removing the ash

8.2. Cleaning the chimney box

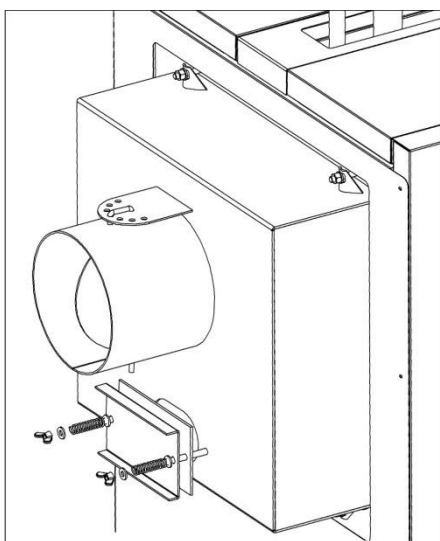

Fig 12. Cleaning the chimney box

To ensure efficient and safe function of the boiler, you must clean the chimney box from ash residues **at least every 3 months**.

The ash box is equipped with a cleaning door for this purpose, as shown in Fig 12. In order to open the door, unscrew the wing nuts, remove the washers and springs that keep it in place.

Clean the interior of the chimney box and remove all the ash and residues.

Put back the door the same way as removed.

8.3. Cleaning burner's chamber

1. The burner can be either at **"Work"** or **"Maintain"** or **"standby"**
 2. Press the button **"MODE/⤵"** continuously till **"STOP MODE"** appears on the screen.
 3. It is written **"Burning off"** till the photo sensor stops to detect fire (3-5 min)
 4. When the photo sensor stops to detect fire, "cleaning procedure takes place for few seconds.
 5. When **"Stop"** appears on the LCD screen, waiting few minutes till the burner cools down.
 6. Open the boilers door, clean the burners tube and close back the door.
 7. By pressing the button **"MODE/⤵"** once changes the operation from **"Stop"** to **"ignition"**.
- By pressing the button **"MODE/⤵"** changes the operation from **"Ignition"** to **"Automatic"**.

**** The frequency of cleaning burner's chamber is depended on wood pellet quality. If premium pellet is used, It is suggested the burner's chamber to be cleaned once a week.**

8.4. Maintenance intervals

8.4.1. Daily maintenance

The pressure of the network must be daily verified to be within the allowed limits. Make sure that all the safety devices and pumps function properly.

8.4.2. Weekly maintenance

The boiler and the burner must be cleaned every 3-4 days or at least once a week, depending on the ash quantity accumulated on the boiler walls and in the heat exchanger. Cleaning procedure must be performed according to the instruction given in the corresponding paragraph.

Check the quantity of ash accumulated in the ash box. The ash disposal can be performed every 1-2 weeks, depending on the ash quantity formed.

8.4.3. Monthly maintenance

Check the doors and the sealing cord. Make sure the contact with the boiler is air-tight. If ash has accumulated on the sealing cord, clean it.

Check the fan and make sure it functions properly. Clean from dust and check that the air passage is clear of obstacles and dust.

Remove the turbinators from the heat exchanger and check their condition.

It is recommended that you clean the chimney box of the boiler and the chimney pipes at least every 3-4 months, in order to assure efficient and safe function of the boiler.

8.5. Basic service procedures

8.5.1. Service after overheating

If overheating occurs, the safety valves of the boiler must open.

Make sure the boiler pump is working. In case of blackout open all the valves of the system to let hot water out of the boiler. In any case a blackout protection UPS is recommended to be installed on the boiler pump.

If the chimney damper is not fully opened, put it in fully open position.



All safety devices must lead to drainage! After overheating, make sure that all the water from the safety devices has drained, and the system has filled with cold water. Check the pressure and the temperature of the boiler.

At overheating, the safety thermostat will activate, and cut electrical supply to the fan. In that case, you need to manually reset the safety thermostat and put the system back in function. Unscrew the plastic cover of the safety thermostat and press the switch. Put the plastic cover back.



Verify the causes of the overheating! If it happens again, check the installation and function of the pumps and safety devices!

8.5.2. Restart the burner after an error

1. Turn off the burner by using the electric switch the burner is connected.
2. Open the boiler's door and check the burner tube.
3. Remove any ashes and impurities from burner fire chamber.
4. Close the door and switch on the controller by using the electric switch the burner is connected
5. By pressing the button "MODE/  " once changes the operation from "Stop" to "ignition".
By pressing the button "MODE/  " changes the operation from "Ignition" to "Automatic"



8.6. Maintenance after long stop

It is necessary to perform a general maintenance and cleaning of the boiler after the heating season. Clean thoroughly all the surfaces of the boiler as described in the corresponding paragraph. Also clean the chimney box, and all the chimney parts where ash might be deposited. After cleaning all the ash, empty the ash box and leave the boiler clean for the next winter season.

After long stop of the boiler, before you put in function you need to perform the following checks:

- Check the condition of the electric cables and the sensors. Make sure they are not damaged. Check that the thermometer indicates the correct temperature and all the thermostats function properly. Make sure the bulbs are properly positioned in the case.
- Make a general check of the chimney and make sure it is clean and free of obstacles.
- Verify the pressure in the heating network and the boiler.



Do not empty the water of the boiler and the heating installation after the heating season! It will corrupt all the installation and especially the boiler.

SERVICE AND MAINTENANCE

- Check that all the valves are working properly. Replace them if necessary. Pay special attention so that all the safety equipment of the boiler functions properly!
- Make sure all the ball valves of the boiler and other relative equipment are open.
- Check the function of the pumps. They might be blocked after long stop.
- Check that there have been no modifications to the installation and the boiler room (ventilation openings, chimney, doors).
- Check the fan and clean from dust. Turn it manually to ensure it is not blocked.

9. TROUBLESHOOTING

Indication	Description	Solution
<p>CH:!!!! WUW:!!!!!! STOP</p>	<p>Malfunction of the water temperature sensors</p>	<p>1. The driver starts up relevant emergency procedures for every sensor in order to prevent the boiler from working beyond the safe range for the installation of the central heating 2. When the boiler cools down, then restart the controller and set the burner on automatic mode.</p>
<p>"Furnace protect"</p>	<p>The temperature in the boiler is higher than 92°C. If the temperature is above 95°C, the STB sensor is activated and the feeder is turned off automatically (the light next to the STB sensor is ON). At any case the pumps are activated to avoid higher temperatures</p>	<p>1. Wait till the boilers water temperature goes down to 60°C 2. Reset the STB sensor, so the light next to it to be OFF. 3. Restart the controller and set the burner at automatic mode.</p>
<p>"Burner alarm"</p>	<p>The temperatures on burner's feeder pipe is higher than 70°C. (Back fire protection) This is happened either the chimney's draught is no the appropriate or the burner hasn't been cleaned.</p>	<p>If the temperature goes down to 60 °C and the photo sensor scans light, then the burner's operation continuous normally. If the temperature goes down to 60 °C and the photo sensor doesn't scan any light, then the signal "Burner alarm" is still on the LCD and you must restart the controller.</p>
<p>"NO pellet"</p>	<p>No pellet on the silo</p>	<p>1. Fill up the silo with pellet 2. Fill the feeder with pellet (Filling feeder procedure) 3. Set the burner at automatic mode</p>
	<p>The feeder doesn't work</p>	<p>If the light next to STB sensor is ON, it means that overheat of the boiler has occurred and STB has turned the feeder OFF. 1. Reset the STB sensor, so the light next to it to be OFF. 2. Restart the controller and set the burner at automatic mode.</p>
	<p></p>	<p>Check the cable from feeder to the controller</p>
	<p>3. Problem during ignition procedure</p>	<p>Burner's tube hasn't been cleaned properly 1. Clean the burner 2. Restart the controller and set the burner at automatic mode.</p> <p>Igniter doesn't work 1. Change the igniter inside the burner.</p>

DECLARAȚIE DE CONFORMITATE EC
CE DECLARATION OF CONFORMITY
(conform cu ANEXA IV din Directiva Europeană 2014/68/EC)
(in compliance with the Annex IV of the European Directive 2014/68/EC)

Producător / The Manufacturer's name:

THERMOSTAHL ROMANIA SRL

Adresa producătorului / Manufacturer's address:

Str. Drumul Osiei 57-59, sector 6, București, România

PRIN PREZENTA, DECLARĂ

Declares that the equipment

Tip: <i>Type:</i>	Cazan de apă caldă cu funcționare pe combustibil solid -încărcare automată <i>Heating boiler for solid fuel, automatically stocked</i>
Obiectul declarației: <i>Object of the Declaration:</i>	ECOTWIN
	Seria / Anul: <i>Serial Number / Year:</i>

ESTE CORESPUNZĂTOR CU CERINȚELE DIRECTIVEI 2014/68/EC-ECHIPAMENT SUB PRESIUNE
MEETS THE REQUIREMENTS PROVIDED BY THE 2014/68/EC DIRECTIVE-PRESSURE EQUIPMENT

ȘI A URMĂTOARELOR DOCUMENTE:

AND THE REQUIREMENTS OF THE FOLLOWING DOCUMENTS:

Produsul este conform cu următoarele standarde: <i>The product is in compliance with the following standards:</i>	
EN 303-5:2012	Cazane de încălzit. Partea 5: Cazane speciale care utilizează combustibili solizi, cu încărcare manuală și automată, cu puterea utilă mai mică sau egală cu 500 kW. Terminologie, cerințe, încercare și marcare <i>Heating boilers.</i> <i>Part 5: Heating boilers for solid fuels, hand and automatically stocked, nominal heat output of up to 500 kW</i> <i>Terminology, requirements, testing and marking</i>
Directive Europene aplicabile echipamentului <i>European Directives applied to the equipment</i>	
2014/68/EC	Directiva Echipament sub Presiune / Pressure Equipment Directive (PED)
2014/35/EC	Directiva Echipamente de joasă tensiune / Low Voltage Directive (LVD)
2014/30/EC	Directiva Compatibilitate Electromagnetică / Electromagnetic Compatibility Directive (ECD)

Informații suplimentare / Additional information:

Toate echipamentele care fac obiectul prezentei declarații au fost testate hidraulic la presiunde de proba egală cu 1,5 ori presiune maxima de lucru, conform cu Anexa I – p. 7.4 a Directivei 2014/68/EC.

As provided by the Annex I - p. 7.4. of the 2014/68/CE Directive, all the equipment object of the present Declaration have been hydraulic tested to a test pressure equal to 1,5 times the maximum allowed working pressure.

Director General
General Director

Matsios Dionysios



România, București, 15 Octombrie 2018



OGRZEWANIE – KLIMATYZACJA

Al. Wojska Polskiego 42 B
05-800 Pruszków e-mail
thermostahl@thermostahl.pl
www.thermostahl.pl